

New Mexico 4-H

# Horse Judging Manual

200.R-48  
New 2016



**Joshua Boyd**

A derivative work based on the AQHA handbook and other sources with express legal permission from the copyright owners



# Youth

# Horse Judging Manual

For Novices to Advanced Evaluators

## **Acknowledgements**

I would like to gratefully acknowledge the following for their contributions and consent to use materials; The American Quarter Horse Association for the use of AQHA rules and pictures excerpted from the 2015 AQHA Handbook for showing and judging.

In addition to the AQHA, I would like to acknowledge Dr. Bob Mowrey, Extension Horse Commodity Coordinator from North Carolina State University for various illustrations used in the production of this manual. I would like to especially acknowledge Alex Ross, Senior Director of Judges with the American Quarter Horse Association for his input and review of this manual. Finally, I would like to acknowledge Mary Hewett for the cover art and assistance with proofing and editing this manual.

## **About the Author**

My name is Joshua Boyd, it was suggested to me by my former department head Dr. Clary, of the Agriculture and Extension Education department, to use my background knowledge and experience to write a horse-judging manual for the coaches and youth horse judges as my Master's Degree project. I have incorporated my nearly twenty-five year knowledge of the horse industry in the development of this manual.

I grew up on a working cow horse and registered Red Angus ranch in central New Mexico where I participated in 4-H horse projects and rodeo. During my years on the ranch, I gained the knowledge from my father, about working naturally with horses and not against horses when starting them.

At the age of fifteen I began breaking horses for outside clients, and for our local veterinarian who owned racehorses. My junior year in high school I moved to Los Lunas to live with my grandparents and joined the FFA horse judging team and participated on the Los Lunas rodeo team. I also had the opportunity to work for a racehorse trainer that lived down the road. Under the guidance of the trainer I learned many aspects of riding and of selecting quality horses. Through this experience I gained a greater knowledge of the anatomy and physiology of the horse. I also gained significant knowledge in the proper management of horses including stabling, grooming, and the proper nutrition for the equine performer.

As my high school years were ending I continued to work for the trainer, Mr. Barber breaking, galloping, and pre training racehorses, and continued breaking and training outside horses for others. After graduating from high school, I began riding racehorses as an apprentice jockey. I rode for seven months and then I obtained a rodeo scholarship to Wharton County Junior College. During my studies at WCJC, I took equestrian related courses, and was also the teaching assistant for the horsemanship class. I competed on the equine evaluation team and had the opportunity to travel to AQHA Congress, Houston Livestock & Rodeo, and other regional equine judging events.

I transferred to Sam Houston State University (SHSU) to continue my studies to pursue a Bachelor of Science in Agriculture & Extension Education. I competed on SHSU's equine evaluation team at regional, state, and national competitions. I also worked periodically for local trainers in the cutting horse business where I gained additional knowledge about the cutting industry.

During my sophomore year, I took a job in Mason Tx. managing the U-180 ranch and breaking and training horses for the Cowboy Stuff Ministry. I then moved to Bandera, Tx. and managed Loma De Blanca guest ranch and was the ranch's head trainer. Daily duties consisted of educating guests about the horses and training young horses to replace older horses in the dude string. I also trained and showed cutting horses for the ranch at local events. I returned to the racehorse industry and rode as an apprentice jockey reaching the status of second leading apprentice jockey in the nation. I enjoyed a ten year career in the racing industry before completing my Agricultural education. Currently I am going through the AQHA's Educational Seminar to become an AQHA judge.

# Table of Contents

<b>Acknowledgements</b>	<b>pg. 2</b>
<b>About the Author</b>	<b>pg. 3</b>
<b>Table of Contents</b>	<b>pg. 4</b>
<b>Preface</b>	<b>pg. 5</b>
<b>The HORSE</b>	<b>pg. 6</b>
<b>Characteristics of a Successful Judge</b>	<b>pg. 7</b>
<b>Learning the Basics</b>	<b>pg. 9</b>
<b>Anatomy: Parts of the Horse</b>	<b>pg. 10</b>
<b>Confirmation Standards</b>	<b>pg. 15</b>
<b>Unsoundnesses, Blemishes, &amp; Conformation Faults</b>	<b>pg. 16</b>
<b>Judging Priorities</b>	<b>pg. 20</b>
<b>Balance</b>	<b>pg. 21</b>
<b>Shoulder</b>	<b>pg. 22</b>
<b>Hip and Barrel</b>	<b>pg. 23</b>
<b>Center of Gravity (Balance)</b>	<b>pg. 24</b>
<b>Balance Worksheet 1:1</b>	<b>pg. 25</b>
<b>Structural Correctness</b>	<b>pg. 26</b>
<b>Incorrectness and Deviation</b>	<b>pg. 27</b>
<b>The Leg</b>	<b>pg. 29</b>
<b>Hindquarters</b>	<b>pg. 32</b>
<b>Refinement and Muscling</b>	<b>pg. 33</b>
<b>Breed Characteristics</b>	<b>pg. 35</b>
<b>Stallions and Mares</b>	<b>pg. 36</b>
<b>Coat Colors and Markings</b>	<b>pg. 37</b>
<b>The Class</b>	<b>pg. 39</b>
<b>Judging Worksheet 2:1</b>	<b>pg. 40</b>
<b>Judging Worksheet 2:2</b>	<b>pg. 41</b>
<b>Judging Worksheet 2:3</b>	<b>pg. 42</b>
<b>Practice Class of Mares</b>	<b>pg. 43</b>
<b>ScanTron Card Sample</b>	<b>pg. 49</b>
<b>Reasons</b>	<b>pg. 50</b>
<b>Terms and Descriptions</b>	<b>pg. 50</b>
<b>IDEAL Show Types</b>	<b>pg. 52</b>
<b>English</b>	<b>pg. 53</b>
<b>Western Pleasure</b>	<b>pg. 63</b>
<b>Terms used when Judging Pleasure Horses</b>	<b>pg. 71</b>
<b>Sample Sets of Reasons</b>	<b>pg. 77</b>
<b>Judging the Reining Class</b>	<b>pg. 79</b>
<b>Terms and Descriptions for the Reining Class</b>	<b>pg. 82</b>
<b>Sample Reining Horse Reasons</b>	<b>pg. 89</b>
<b>Reining Patterns</b>	<b>pg. 90</b>
<b>Credits</b>	<b>pg. 91</b>

# **PREFACE**

## **How to Use the Horse-Judging Manual**

This manual is designed to serve as a guide for the development of skills as an equine judge. The successful candidate will develop skills and terminology that will enable him or her to compete on competitive horse judging teams. The illustrations and suggested terminology maybe used to describe any breed individual regardless breed characteristics.

The anatomy (parts of the animal), structure, balance, and muscle of the horse are universal for all breeds. Judging criteria are the generalized guidelines that have endured since the inception of horse judging. It is suggested that the student first learn the anatomy of the horse. As stated above all horse breeds are anatomically the same although each breed will have unique characteristics that set it apart from other breeds.

Secondly, the student should become familiar with poor animal structures, which are known as unsoundness. This unsoundness is the faults in an animal's conformation that lead to an inability of the animal to perform effectively in events or breeding.

The student should then read the chapter on conformation and the importance of a horse that demonstrates correct conformation and breed characteristics. Once the student is familiar with the horse, then he or she should learn the correct terminology for the horse's qualities. Without the proper terminology then the student will be unable to give a set of reasons in a knowledgeable and suitable manner.

The chapter on reasons explains how to describe what you have already learned about the horse's anatomy, characteristics, faults, blemishes, and qualities that make the animal either suited for or unsuited for specific events. In judging the animal you are forming an opinion as to the ranking of the animals based on specific characteristics that are recognized in the horse industry.

Finally, the student should review the chapters covering the horse judging classes and the sample reasons for each class. The student should also take advantage of the worksheets that are provided to practice their judging skills.

Students are encouraged to learn the parts of the horse, the importance of balance, soundness, and structural correctness of the horse and the terminology used in judging. This manual supplies many examples and definitions that will benefit the individual or team with horse judging. Best of luck with your judging endeavors and perhaps, your future career in the horse industry.

## “HORSE”

**H**orse, judging contests allow students an opportunity to evaluate horses as they are exhibited in halter and performance classes at various competitive levels. The 4-H and FFA organizations conduct contests throughout the state and at national competitions. Members of a judging team spend numerous hours in preparation for upcoming contests, and in doing so acquire many important life skills. Decision-making, problem-solving, critical thinking and public speaking are skills learned and developed through the educational process. Teams practice throughout the year for the spring horse judging contests where they will travel throughout the state to compete. Successful qualifiers will often have an opportunity to attend the state horse judging competition at New Mexico State University in Las Cruces. 4-H members who qualify for national competition will compete at the Western National Roundup. FFA members who qualify for national contest will compete at the National FFA convention.

**O**rganizations, The two most prominent youth agricultural education organizations are the 4-H and the FFA. Students may begin 4-H competition as young as 8 years old and continue in 4-H through high school. A student may enter the National FFA organization at the age of 12 or in seventh grade and compete throughout high school. A student may continue his or her horse judging endeavors with an intercollegiate horse evaluation team at an agricultural college.

**R**easons, are a fundamental to the horse judging process. Individuals of a team are required to logically validate the placement of a class of horses to a reasons official in a self-confident and knowledgeable manner. Public speaking skills are an important part of giving reasons and demonstrate the team member's ability to be persuasive, express good memorization skills, and exhibit a working knowledge of the proper terminology.

Students with good public speaking abilities win many contests because they give a set of reasons that paints a picture to the judge of the horses' qualities. A person with average class placings and high reasons scores will often excel over high placings and average or poor reasons.

**S**tudents, which compete in horse judging contests, have a greater chance of being awarded scholarships at College or University institutes who are looking to improve their school's equine evaluation teams.

**E**xcellent, opportunities exist for those who can judge the qualities of an animal. These individuals are favored for jobs in the equine industry and as university, state, regional, and national judges for open and breed classes

## **Characteristics of a Successful Judge**

The American Quarter Horse Association (AQHA) competitive horse-judging manual describes the necessary characteristics of a successful horse judge as a person who possesses the following:

1. A clear mental picture of the ideal or type, and an ability to recognize undesirable traits.
2. Ability to employ deductive reasoning and incorporate practical considerations in a positive manner.
3. The mental and physical stamina necessary to make logical decisions under pressure.
4. The ability to effectively defend the placing of a class.

## **An Abbreviated Description of Horse Judging**

A judge only has a few minutes to review each horse and determine if that horse fits near to the ideal or type of horse. During those few moments, the judge must immediately recognize the undesirable traits that will ultimately affect placement of the class. The judge or team should give clear and concise reasons for the placement of the class. The judge should verbalize traits in a respectful, logical, and convincing manner. The judge should recognize the desirable and undesirable traits and be capable of defending their decision for all halter and performance classes.

Halter horse judging is a positive evaluation of the individual's balance, structural correctness, breed and sex characteristics as well as balanced and proportional muscling. The ideal horse shown at halter is a horse that should possess the following characteristics that result in a pleasant eye appeal that is the result of a harmonious blending of:

- An attractive head
- Refined throatlatch
- Well-proportioned trim neck
- Long sloping shoulder
- Deep heart girth
- Short back
- Strong loin and coupling
- Long hip and croup
- Well-defined and muscular stifle, gaskin, forearm and chest
- The horse should be a balanced athlete that is muscled uniformly throughout
- These characteristics should be combined with straight and structurally correct legs and feet that are free of defects

## The Ideal Horse



Picture and description of judging characteristics used with permission from the AQHA.

A halter horse judge has a responsibility to find the animal that is the best positive combination of the characteristics described. The halter class is where the horse is judged based upon its conformation and similarity to the IDEAL as described by the AQHA.

The junior judging candidate should aspire to learning these characteristics and practice judging a horse for these attributes whenever an opportunity arises.

The pictures of various horses, as shown in this manual, offer the judge an opportunity to start learning the parts of the horse and what the ideal horse looks like. As you go through the manual you will see diagrams and pictures of horses with good and bad characteristics as well as diagrams of defects and unsoundness that takes away from the quality of the animal.



## Learning the Basics

- 1) **Parts of the Horse (Anatomy)**
- 2) **Conformation Standards**
- 3) **Unsoundnesses and Blemishes**

(An Ideal or Type: American Quarter Horse)



(Picture reproduced with permission from the AQHA)

This chapter will cover the anatomy of the horse as well as identification of unsoundness and blemishes that take away from the desirable traits of the horse. The horse should possess certain characteristics that make it an ideal candidate for halter or performance classes.

## 1) Parts of the Horse (Anatomy)

Below is a diagram from the AQHA horse manual that outlines the parts of a horse that a judge needs to become very familiar with so he or she will be able to give sound and intelligent reasons.

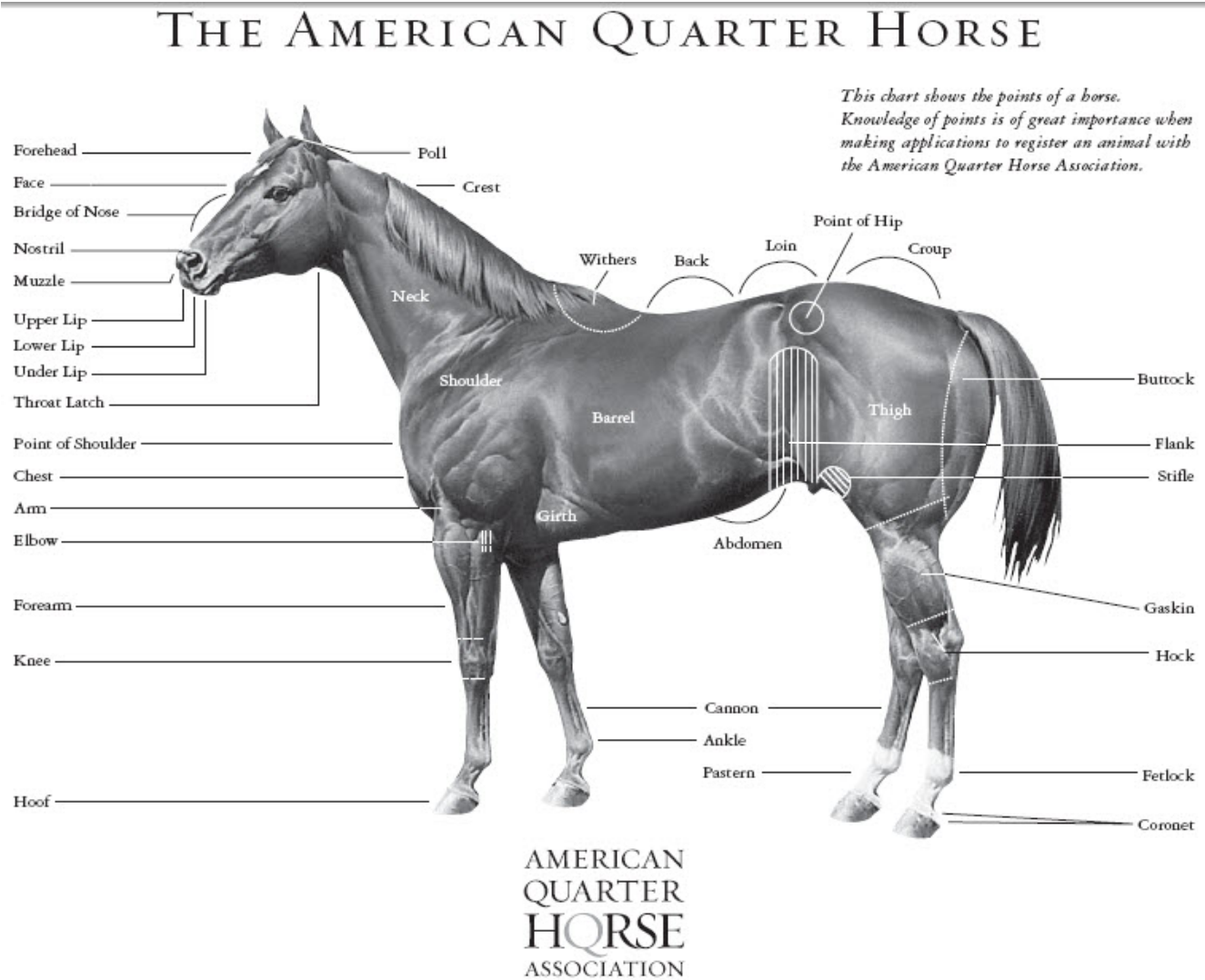

©HT 1994 THE AMERICAN QUARTER HORSE ASSOCIATION

P.O. Box 200, Amarillo, TX 79168

Learning the terms of anatomy from the above diagram will allow the judge to develop a sound foundation by being able to locate and label the external body parts. The ability to correctly identify the body parts allows the judge to reference the horse using common terms used in the horse industry.

The following pages will cover various segments of the horse's anatomy and the desirable characteristics that you, as a judge, will be looking for when judging a class of horses.

The following descriptions are reproduced from the AQHA *Showing and Judges Manual* with the permission of the AQHA:

**HEAD** - The head of an American Quarter Horse reflects alert intelligence. He has a short, broad head topped by small ears; kind wide-set eyes; large nostrils; short muzzle; and firm mouth. Well defined jaws give off an impression of strength.



(Image reproduced with permission from Dr. Bob Mowrey: “Teaching Youth an Equine Conformation Judging System”)

The selection of a horse by how pretty headed it is has nothing to do with the physiological aspect of that horse. Horses without attractive heads can still function well. Horses’ heads have eleven key functions. Starting at the top of the head and between the ears the following are described as the following.

**POLL**- Which is the bony distinction between the ears. Except for the ears the poll is the highest point on the horse’s body when it is standing with its head up.

**EARS** – Located at the top of the horses’ head and situated to the left and right of the poll. Besides hearing a horses’ ears indicate alertness and anger. The ears should be set at the top of the head and be equally shaped and proportioned to the size of the head with an alert, attractive appearance.

**FOREHEAD** – The forehead should be broad, full, and flat.

**FACE** – The face is the area between the forehead and bridge of the nose and located between the eyes. The face should be full and flat.

**BRIDGE of NOSE** – Located between the face and nostrils. The bridge of the nose should be flat and transition smoothly between the face and nostrils. The Arabian breed have a dished bridge between the face and nostrils. Horses with a hump in the bridge are referred to as Roman-nosed.

**NOSTRIL** – The nostrils should be capable of wide dilation to permit the maximum inhalation of air, yet be fine in appearance.

**MUZZLE** – The head should taper to a small muzzle, a nice-headed horse will have a defined muzzle which flares into a refined and prominent jaw. The lips should be firm and the lower lip should not have the tendency to sag.

**JAW** – Stallions will have a larger, deeper, jaw than mares, expressive of common male sex characteristics.

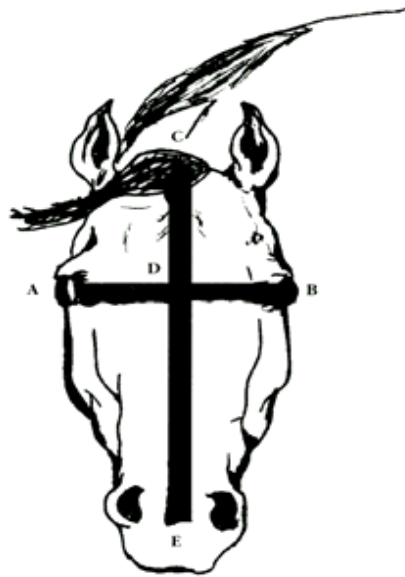

To measure a horse's head you must start by drawing a horizontal line between the eyes.

- Facing the horse's head label the eye to your left "A" and the eye on your right "B".
- Draw a line vertically from the poll to the muzzle between the nostrils. Label this line "C" at the poll, "D" at the intersection of the horizontal line and the vertical line, and "E" at the muzzle.
- The distance horizontally from A to B should equal half the distance vertically from C to E.
- The measurements should come out proportional to form an even and balanced head on the horse.
- Several characteristics that suggest trainability and should be considered sound are pig-eyed, bright full eye, parrot-mouthed and monkey-mouthed.

**NECK** - The head of the American Quarter Horse joins the neck at a near 45-degree angle, with a distinct space between jawbone and neck muscles allowing him to work with his head down without restricting his breathing. The medium length, slightly arched, full neck blends into sloping shoulders.



(Image reproduced with permission from Dr. Bob Mowrey: "Teaching Youth an Equine Conformation Judging System")

**RATIO-** The ratio is calculated as 2:1. The crest should be 2x the length measured from the poll to the mid point of the withers. The underline of the neck should be 1x the length measured from the Throat Latch to the Neck Set.

**NECK** – Light-weight horses should have reasonably medium/long necks for good appearance and proper balance. It should blend smoothly into the withers and the shoulder does not appear to emerge between the front legs.

**CREST** – The crest is the curved top line of the neck located from the poll to the withers moderately lean in mares but inclined to be fuller in stallions.

**THROAT LATCH** – The neck should be fine at the throat latch to allow the horse ease of flexion.

# Top Line = Balance



(Image reproduced with permission from Dr. Bob Mowrey: "Teaching Youth an Equine Conformation Judging System")

**RATIO-** The ratio is calculated by measuring the length of the topline from mid withers to the point of hip. The top ratio should be 1x in length of the underline which is measured from the elbow to the stifle. Which should be 2x's the length of the top line.

**WITHERS** – The withers is the prominent ridge where the neck and the back join. At the withers, powerful muscles of the neck and shoulders attach to the elongated spine of the second to sixth thoracic vertebrae. The height of a horse is measured vertically from the withers to the ground, because the withers are the horse's highest constant point.

**BACK** – The back extends from the base of the withers to where the last rib is attached. The back will determine the stride of a horse's, and how smooth the gait will be in stride.

**LOIN** - The loin or coupline is the shortest area joining the back to the powerful muscular croup (hind quarters).

**CROUP** – The croup (rump) lies between the loin and the tail head. When one is looking from the side (profile) or back, it is the highest point of the hindquarters.

## 2) Conformation Standards

**STANCE** -The American Quarter Horse normally stands at ease with his legs well under him, which explains his ability to move quickly in any direction.

**ACTION** - The American Quarter Horse is collected in action enabling him to turn or stop with noticeable ease and balance, with his hocks always well under him.

**HEAD** -The head of an American Quarter Horse reflects alert intelligence. He has a short, broad head topped by small ears; kind wide-set eyes; large nostrils; short muzzle; and firm mouth. Well-defined jaws give off an impression of strength.

**NECK** -The head of the American Quarter Horse joins the neck at a near 45-degree angle, with a distinct space between jawbone and neck muscles allowing him to work with his head down without restricting his breathing. The medium length, slightly arched, full neck blends into sloping shoulders.

**SHOULDERS** -The American Quarter Horse's good saddle back is created by medium-high distinct withers, extending back and combining with deep sloping shoulders. This helps keep a saddle in the proper position for balanced riding.

**CHEST AND FORELEGS** -As shown by his heart girth and wide-set forelegs, the American Quarter Horse is deep and broad chested. His smooth joints and short cannon bones are set on clean fetlocks, and medium length pasterns are supported by healthy hooves. The powerfully muscled forearm tapers to the knee, whether viewed from the front or back.

**BACK** -The short back of the American Quarter Horse is full and powerful across the kidneys. The barrel is formed by deep, well-sprung ribs, which extend to the hip joints. The underline, or abdominal area, should rise cleanly to the flank.

**HIND QUARTERS** - Viewed from either side or the rear, the hindquarters are broad, deep and muscled fully through the thigh, stifle and gaskin down to the hock. The thickly muscled hind legs indicate the American Quarter Horse's great power and speed.

When viewed from the rear, there is great width extending evenly from the top of the thigh to the gaskin. The hocks are wide set, deep and straight.

**BONES, LEGS AND HOOVES** -The flat, strong bones are free from fleshiness, puffs and injuries. The hooves are well-rounded and roomy, with deep open heels.

### 3) Unsoundnesses, Blemishes, & Conformation Faults

The unsoundnesses in horses are primarily caused, by conformation faults. Regardless of the breed, the ideal or type of desirable horse is determined by conformation. Injuries are most often directly related to the stress from unsoundnesses and conformation faults. The faults in conformation may cause a horse to stress in other areas of their body where they would otherwise not if their conformation and structure were correct. Standards have been set for judging conformation in an effort to stress the importance of a structurally correct horse so that the horse may function in its jobs, and eliminate those individuals with the most unsoundnesses, blemishes, and faults.

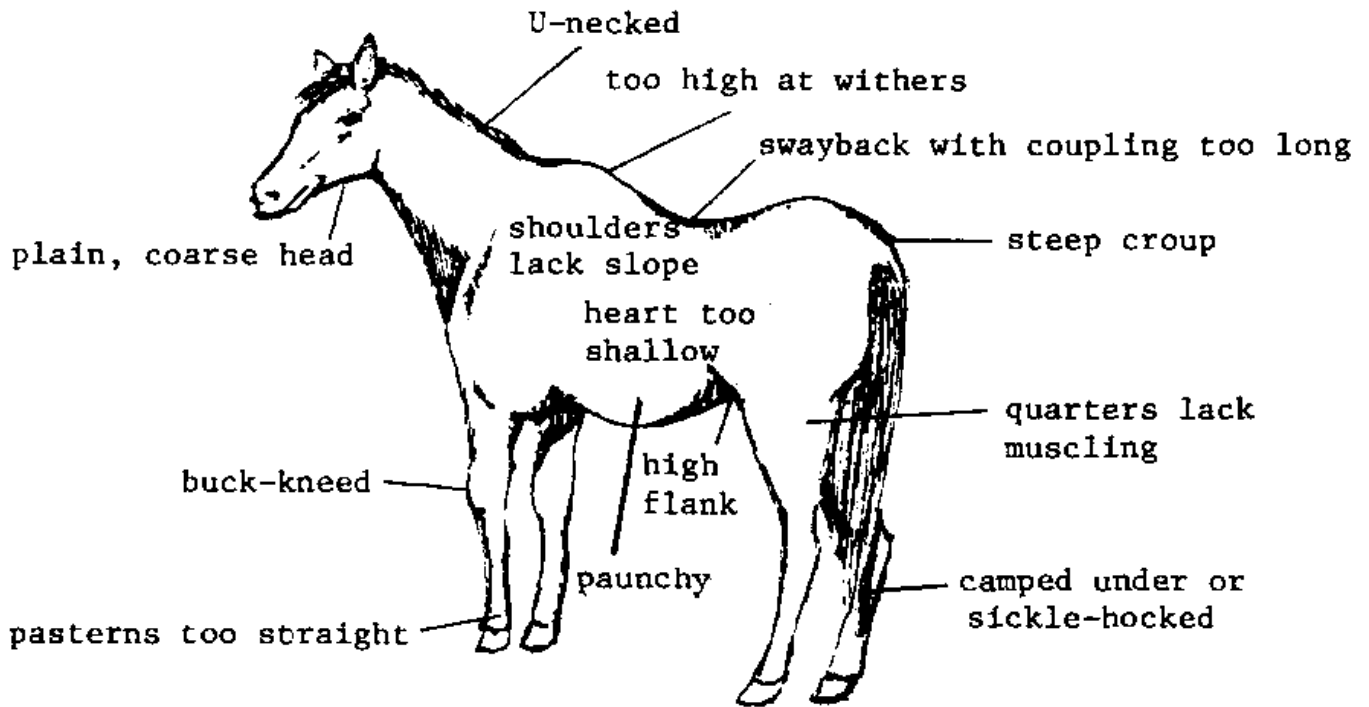

#### Description of Faults

**Plain, coarse head-** Structure of the head is not attractive plain in appearance and has rough transitions from poll to forehead narrow eyes, and has a roman nose(hump in the bridge of the nose). Jaws are either extremely large or narrow with no distinction.

**Ewe-necked (U-necked)-** Internal structure of the neck causes the neck to bend in the upward direction unlike most horses that arch in the normal downward position. This fault can be found in Thoroughbred and Arabian breeds, but not limited to be found in any breed. Long-necked horses are susceptible to this fault. A ewe-necked horse will cause the rider difficulties with control and have problems with collection in the horse's body. The ewe-necked horse also has tendencies to brace the bit and become hard mouthed.



**Too high at withers** – High at the withers is commonly a result of light muscling which can be a result of defective development of the muscle. Step shoulder's contribute to the withers being too high. Horses that are too high at withers are prone to bruising, and distribute the weight and angle of the saddle that causes a horse to become unsound.

**Swayback with coupling too long**- Weak topline that hollows out in the back between the withers and loin. The loin and the coupling are what reassign the movement of the hindquarters through the back and forward. Coupling too long will cause a loss in power converted from the hindquarters because its vertical line drops and hollows out.

**Steep croup**- Horses with steep croup are shorter usually this reduces the range of motion to generate speed. The shorter the croup provides a smaller amount muscle attachment points.

**Quarters lack muscling**- Lightly muscled horses in the hindquarter will be narrow from stifle to stifle, and gaskin muscles will not be well defined which should be the widest part of the horse's muscling. Loin muscles should be well defined but not bunched.

**Camp under or sickle-hocked**- Greater angulation of the hock joint. The hind legs become evident to be under the horse more from the hock down.

**High flanked**- The shape of the flank involves definite attributes in the horse's conformation, and ability under saddle. Deep and well proportioned flank that does not pinch or narrow is preferred. High flanked or shallow flank horse's organs and bowels are confined to limited room. A common belief is that lungs are restricted and not desired in competition do to lack of stamina.

**Paunchy**- Horses that are paunchy, have a large and protruding belly. These types of horses require more grain based feeds and less hay than horses doing slow or heavy work.

**Heart too shallow**- The heart girth measured from the top of the withers to the bottom of the chest floor which is located behind the elbow of the frontleg. Heartgirth is located where a cinch or girth would go if the horse was saddled. An unbalanced horse from the underline viewed from the front to the back are referred to as heart too shallow. Very seldom will you see a heart too deep. Incorrect balanced horse from this way is heart too shallow or shallow in the heartgirth.

**Pastern too straight**- Normal front pastern angle 45 degrees, this is measured from the horizontal line of the ground. Too straight of a pastern angle causes pressure from jarring to the fetlock joint and can also affect the navicular bone.

**Bucked kneed**- Structural fault of a horse's knee sets forward of the line that intersect the cannon bones. Horses may have problems resulting with bowed tendons.

**Shoulder lack slope-** Steep shouldered horses that have an angle more than 50 degrees. Length of stride is decreased and makes them rough to ride, this also increases pressure on the forelegs resulting in leg injuries.

## Common Unsoundnesses

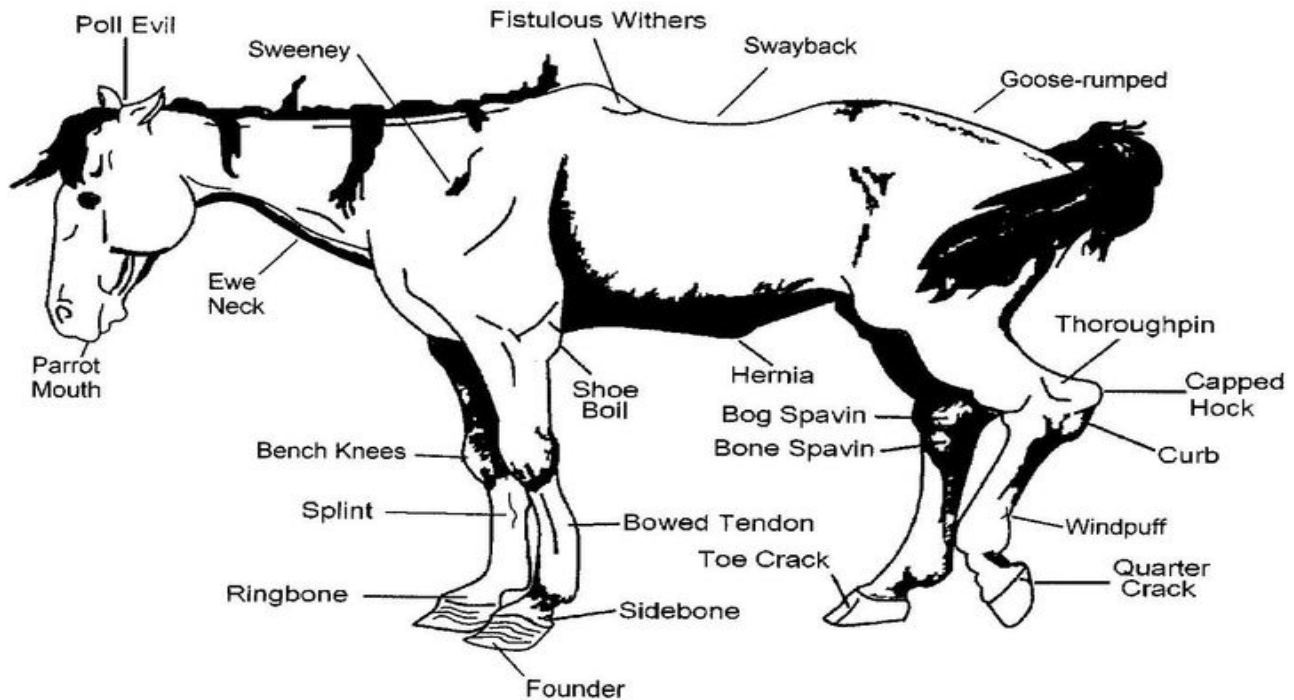

**Poll Evil-** Inflammation or inflamed at the poll area caused by a blow and bruising.

**Parrot Mouth-** Lower jaw is shorter than the upper jaw which is a hereditary condition.

**Ewe Neck-** Internal structure of the neck causes the neck to bend in the upward direction.

**Sweeney-** Shoulder muscle shrinkage or atrophy, shoulder is flat and blade, scapula visible.

**Fistulous Withers-** Inflammation or infection caused by bruising that leads to an abscess.

**Swayback-** weak topline that hollows out in the back between the withers and loin.

**Goose-rumped-** Croup sharply slopes from the loin to the tail head, shortening length of stride.

**Thoroughpin-** Puffy swelling in the hollow area above the hock, injury or faulty conformation.

**Capped Hock-** Point of the hock has soft fluid-filled or firm swelling, kicking or poor bedding.

**Curb-** Ligament enlargement at the upper rear part of the cannon underneath the hock.

**Windpuff-** Fluid-filled swelling at the fetlock joint that is puffy, by heavy work or stress.

**Quarter Crack-** Crack on the inside & outside of the quarter from coronet and down the hoof.

**Toe Crack-** Deep crack at the toe in the hoof, from coronet runs down through the entire hoof.

**Bon Spavin-** A bony enlargement located inside and at the front lower hock.

**Bog Spavin-** Natural depression on the front inside of the hock joint that is a soft swelling.

**Hernia-** Protrusion of an organ or tissue through the abdominal wall or another body opening.

**Shoe Boll-** Irritation to the skin, causing inflammation of the elbow on the upper rear front leg.

**Bowed Tendon-** Enlargement of any or all of the tendon and ligaments behind the cannon.

**Sidebone-** Bony enlargement above and rear of the hoof, result of cartilage turning to bone.

**Founder-** (Laminitis) an inflammation of the hoof in the sensitive laminae of the foot.

**Ringbone-** Arthritis enlargement on the bones and or joints of the pastern.

**Splint-** Bone like enlargement on the inside of the front cannon bone, any where on the splint.

**Bench Knees-** Structural fault of a horse with cannon bones set too far to the outside of the knee.

# Judging Priorities

## Specific Qualities to Look for When Judging the Horse

- All Horses
  - Balance and Quality
  - Structural Correctness
  - Refinement
  - Muscling
  - Breed Characteristics

## Additional Qualities to Look for When Judging Breeding Classes

- Stallions & Mares
  - Sex Characteristics
    - Femininity and Masculinity
  - Producing Mares
    - Broody Characteristics
  - Stallions
    - Stud Qualities

# BALANCE

Balance is the single most important characteristic in equine selection. It is determined by the skeletal framework of the animal being judged. When judging, it is important to attempt to visualize and evaluate the skeleton of the horse underneath its muscle and other tissues. Because it is sometimes difficult to visualize the skeletal framework of the animal being judged, there are several easy reference points to evaluate balance.

## Determining Balance:

Divide the equine into thirds, thereby giving you a visual guide to measure balance



(Image reproduced with permission from Dr. Bob Mowrey: "Teaching Youth an Equine Conformation Judging System")

The image above gives a visual of how the thirds should be divided between the shoulder, barrel and hip. Balance can also be determined by the slope of the shoulder and hip that range from 45° to 50°. The pastern angles should also correspond.

This process can be visualized in the trapezoid image below:

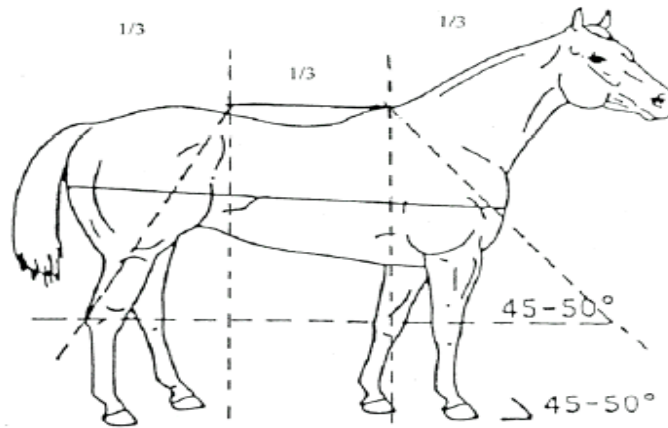

## Trapezoid

(Image reproduced with permission from Dr. Bob Mowrey: "Teaching Youth an Equine Conformation Judging System")

## Shoulder:

The American Quarter Horse's good saddle back is created by medium-high distinct withers, extending back and combining with deep sloping shoulders. This helps keep a saddle in the proper position for balanced riding. Angle of pasterns from the fetlock to the toe of the hoof at the horizontal plan of the ground should correlate with the shoulder at 45-50 degrees.

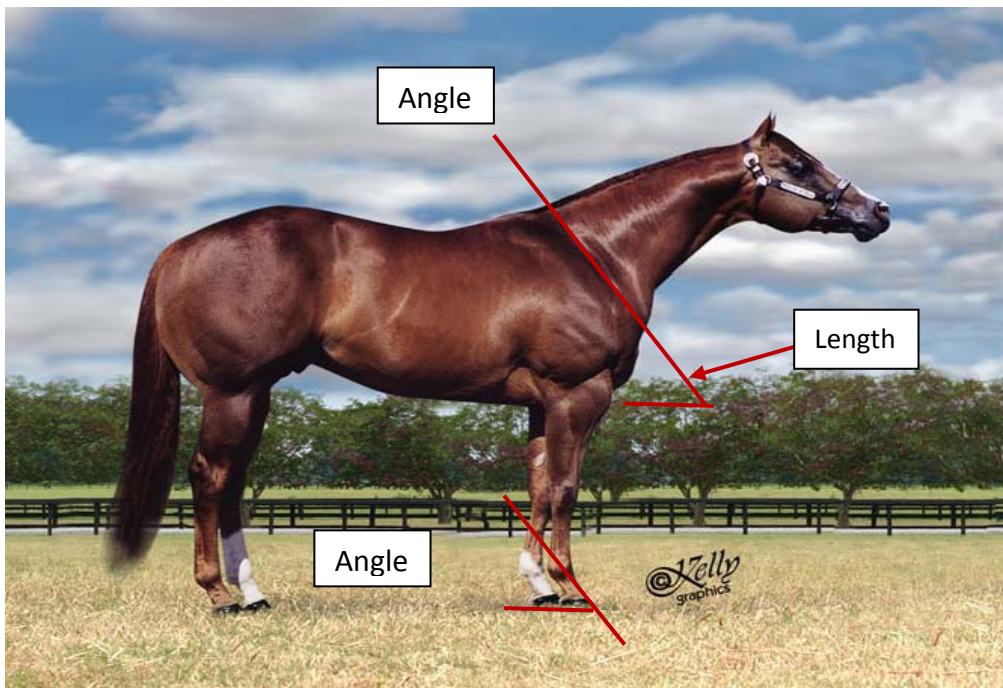

## HIP + BARREL = Volume, Capacity, & Frame



(Image reproduced with permission from Dr. Bob Mowrey: “Teaching Youth an Equine Conformation Judging System”)

### **Heart Girth and Hip:**

Heart girth is measured from the top of the withers to the point of the elbow. The hip is measured from the flank to the buttocks and the top of the croup to the base of the stifle. These should be of equal length. Depth of the heart girth and the boxed hip should be the same length as the legs in regards to proper balance.

### **The Ribcage:**

The ribcage should be flat directly behind the shoulder. The barrel should be well-rounded, and full over the ribcage with evidence of spring of rib. This provides a broad barrel with volume and capacity.

### **Rear Flank:**

The rear flank provides balance to the middle, and should be deep. The depth in the flank contributes to conformation and balance. Flanks are considered best in horses that are fleshe and extremely fit.

# Determining the Center of Gravity

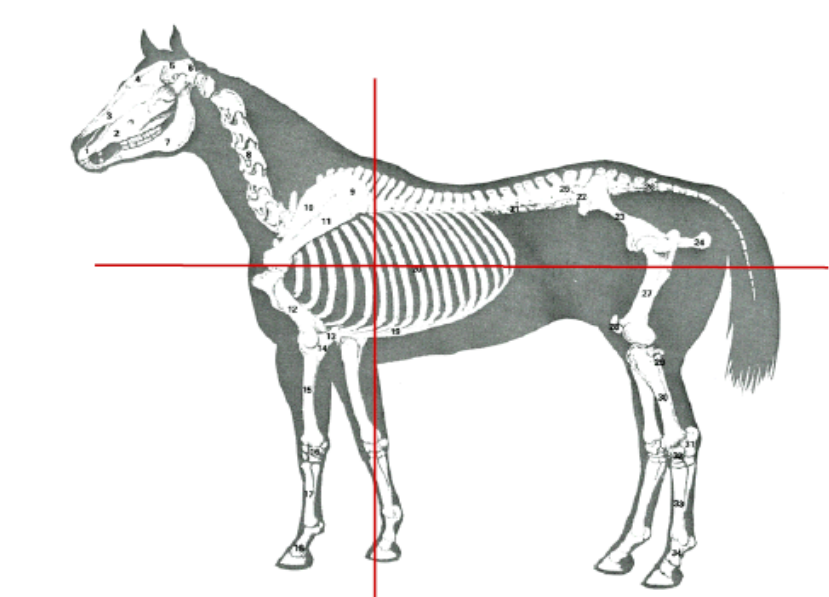

(Image reproduced with permission from Dr. Bob Mowrey: "Teaching Youth an Equine Conformation Judging System")  
(Information reproduced from "Selecting a Saddle." Department of Animal Sciences, University of Missouri-Columbia)

The location of the horse's center of balance depends on a combination of speed and degree of collection. For a standing or quietly walking horse, it is slightly behind the heart girth and below the withers. If a horse is moving at a trot or canter, the center of balance shifts slightly forward, and it moves even more forward when the horse is galloping or jumping. If a horse is highly collected, the center of balance will be farther back, regardless of gait, than if the horse is in an extended frame. For movements such as a rein back or the levade, the center of balance of horse and rider may be further back than at a standstill, due to the shift of weight and balance to the hindquarters of the horse.

## Movement



Front/Rear View=Trueness of Stride  
Side View=Length of Stride, Animation, etc.



# Determining Balance

(Worksheet 1:1)

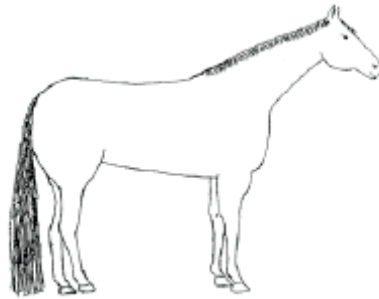
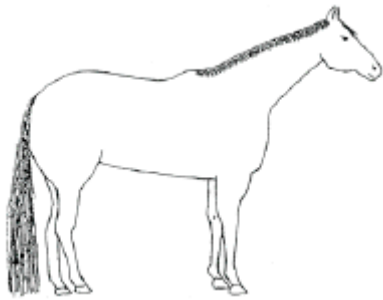

\_\_\_\_\_

\_\_\_\_\_

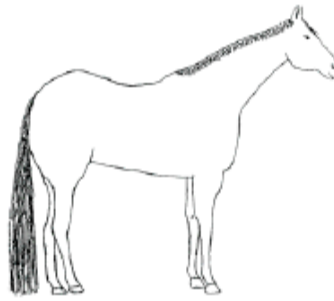
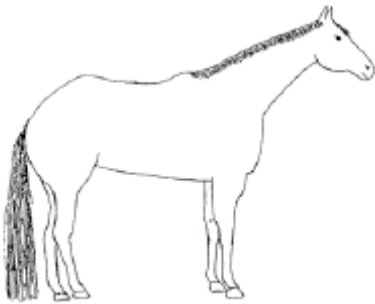

\_\_\_\_\_

\_\_\_\_\_

**Place the following terminology based on qualities of balance in the line provided:**

- Steep Hip (undesirable)
- Short strong back (desirable)
- Long Back (undesirable)
- Low Back (undesirable)

## Structural Correctness

Structural correctness of feet and legs is a major area of consideration in judging. When standing beside the horse the judge drops an imaginary line from the point of the buttocks to the ground. Ideally, the line should touch the hocks, run parallel to the cannon bone, and be slightly behind the heel. The horse with too much angle to his hocks is referred to as *sickle-hocked* and the horse that is straight in his hocks is *post-legged*. Ideally, when viewed from the rear any horse should be widest from stifle to stifle.

Another imaginary line from the point of the buttocks to the ground should bisect the gaskin, hock and hoof. It is not critical that a horse be perfectly straight from the ankles down when viewed from the rear. Most horses naturally stand with the cannons parallel and slightly toed-out at the hooves. This allows the horse's stifle to clear the ribcage when in flight, thereby giving longer stride and freer movement.

When a horse is bowed-in at the hocks and the cannon bones are not parallel, this is referred to as being *cow-hocked*. A horse that is *over at the knees* is *buck-kneed* and a horse the *back at the knees* is *calf-kneed*. Being calf-kneed is a serious flaw and should be looked for when judging structural correctness.

When a horse is viewed from the front an imaginary line from the point of the shoulder to the toe should bisect the knee cannon bone and hoof. The hoof should point straight ahead. When a hoof toes-out this is referred to as *splay-footed* and will always *wing-in*. When a horse toes-in it is referred to as *pigeon-toed* and the horse will *paddle-out*.

The most serious of these conditions is the horse that wings-in, because it has a tendency to stike its leg with the opposite foot when it travels. Finally, if the cannon bone is off-centered to the outside this is referred to as being bench-kneed.

The Ideal horse will not have any of the listed flaws in structural correctness, and as the judge you must be aware of these tendencies that take away from being an ideal specimen. The following pages will give you examples of the deviations from structural correctness.

# STRUCTURAL INCORRECTNESS AND DEVIATIONS FROM THE IDEAL

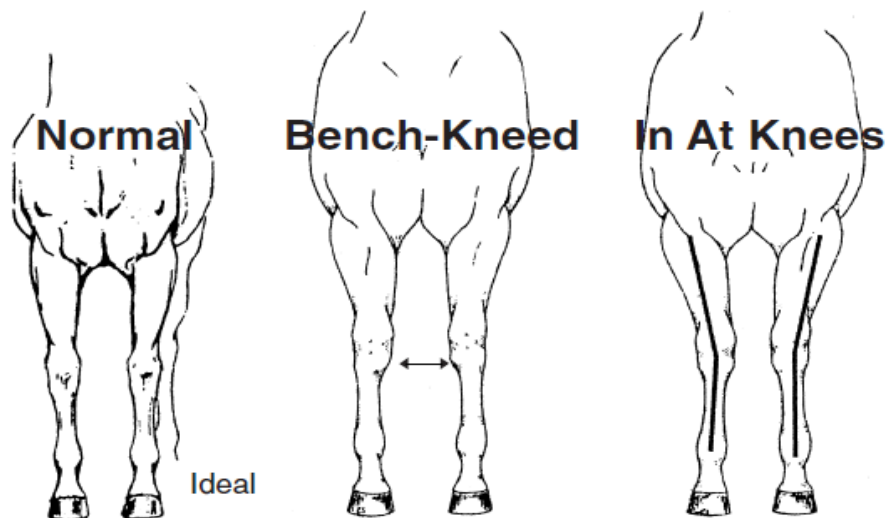
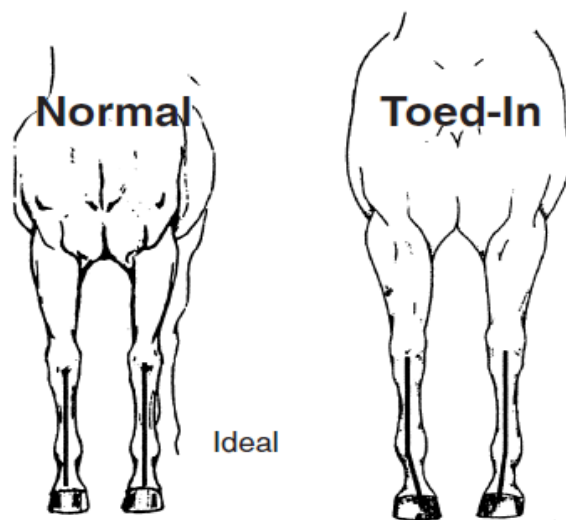
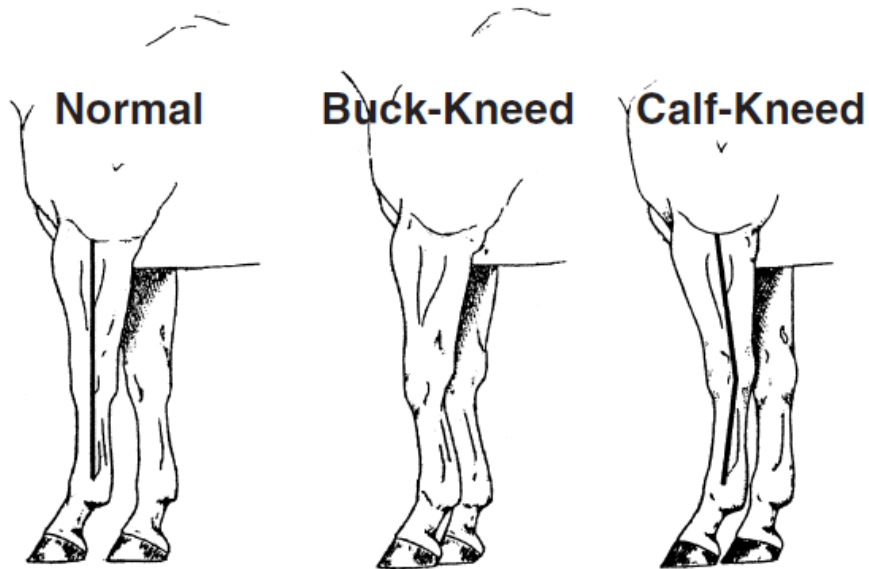

# Foot Fall Patterns

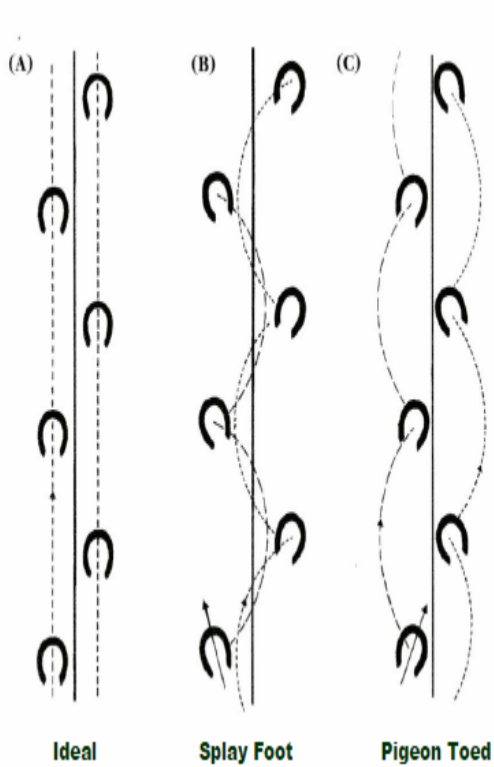

Front Legs

*Viewed from the side*

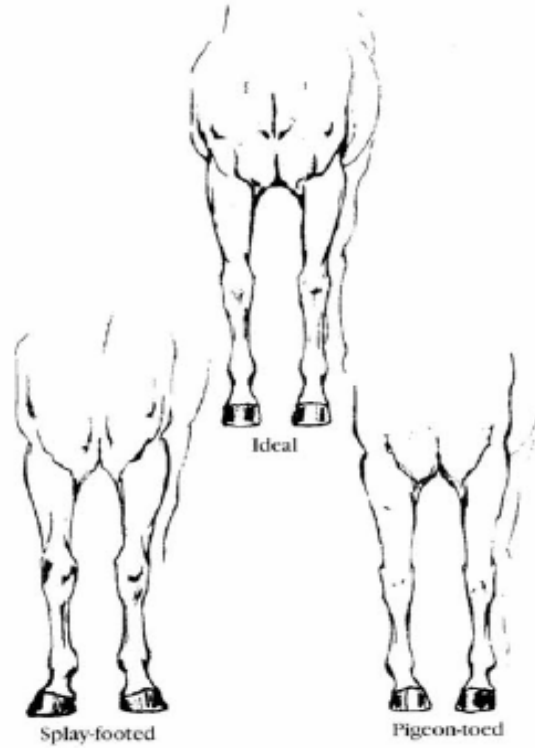

Front Leg Structural Faults

*Viewed from the front*

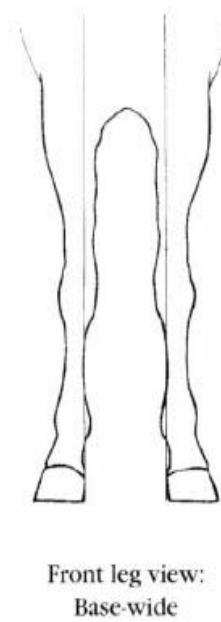
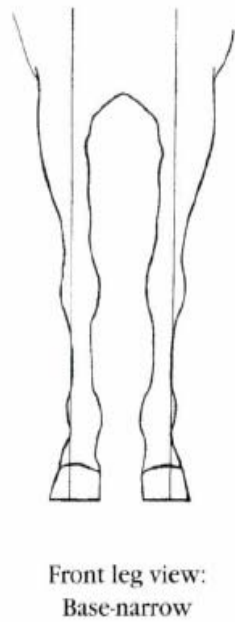
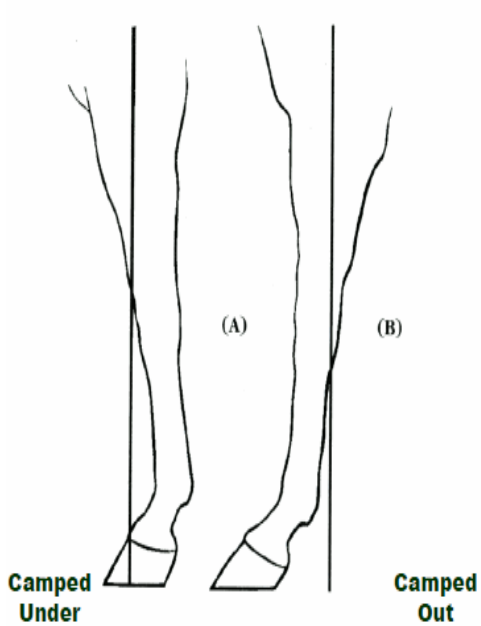

## The Leg *Side View*

**BONES, LEGS AND HOOVES** –The flat, strong bones are free from fleshiness, puffs and injuries. The hooves are well rounded and roomy, with deep open heels. The correct angles can be imagined and are demonstrated below.

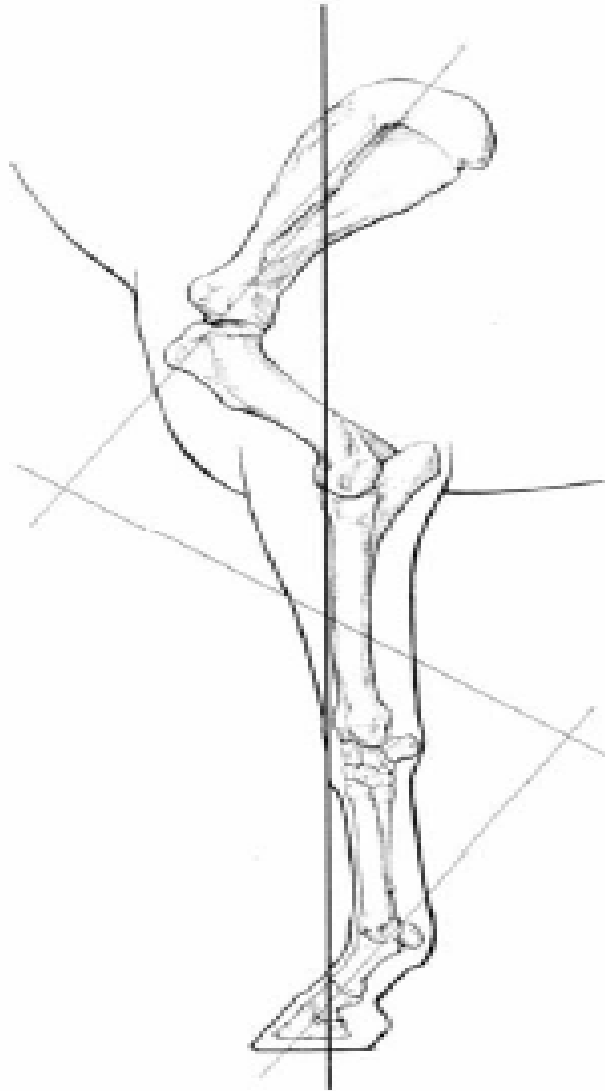

(Image reproduced with permission from Dr. Bob Mowrey: "Teaching Youth an Equine Conformation Judging System")

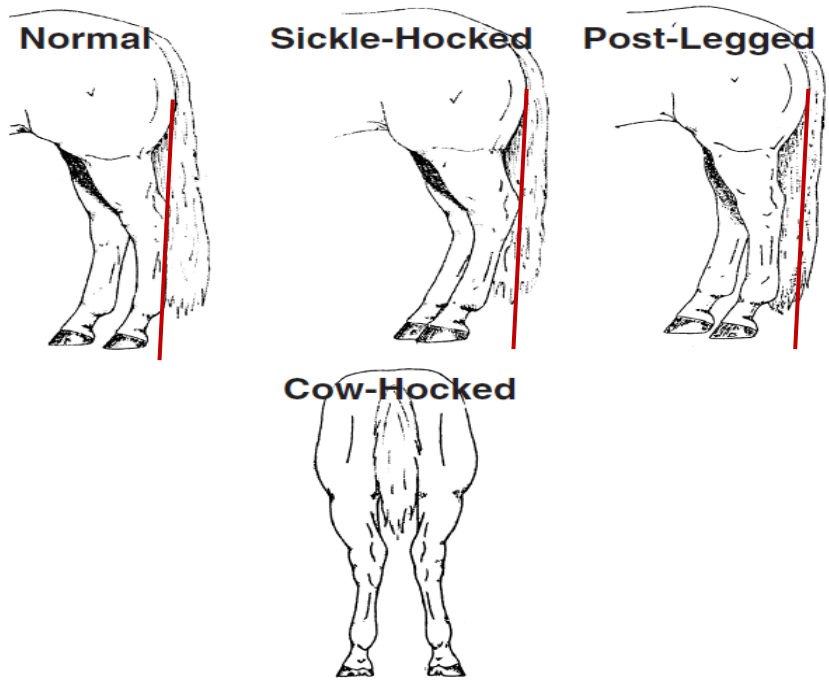

(Images reproduced with permission from Dr. Bob Mowrey: "Teaching Youth an Equine Conformation Judging System")

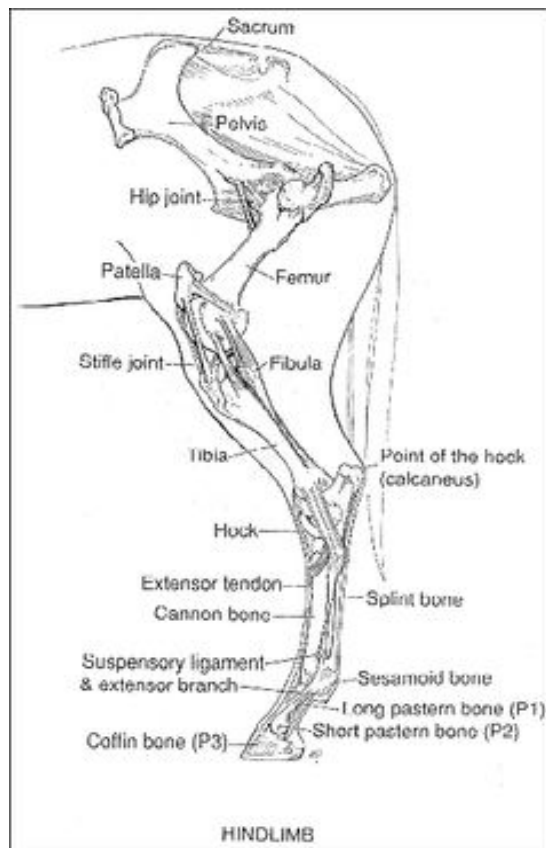

## Rear View of Structural Correctness

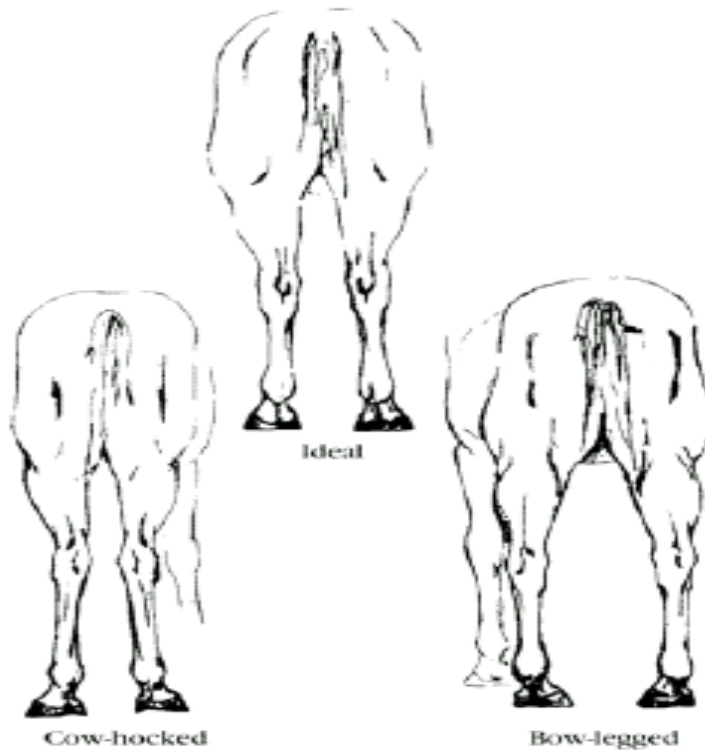
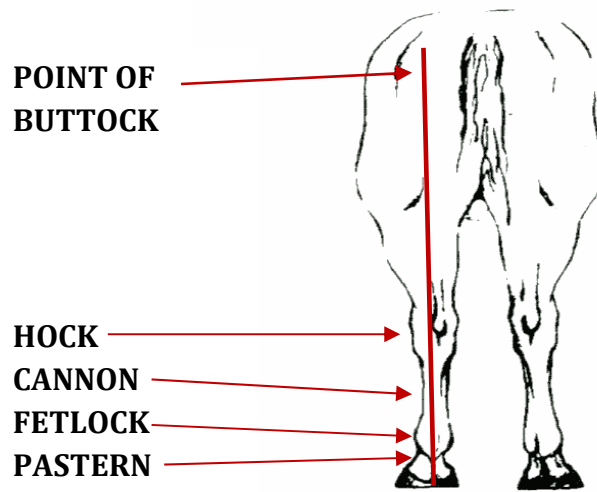

(Images reproduced with permission from Dr. Bob Mowrey: "Teaching Youth an Equine Conformation Judging System")

## Structure of the Hind Quarter

### **(Stock-Type) Croup/Hip:**

Evaluating the Croup/Hip, is crucial when determining the horses ability to athletcly perform. Power from a large muscular croup/hip provide a horses forward thrust and ability to carry weight. Most performance riding disciplines have maneuvers that require large, full, heavily muscular croup/hips that are quick to respond.

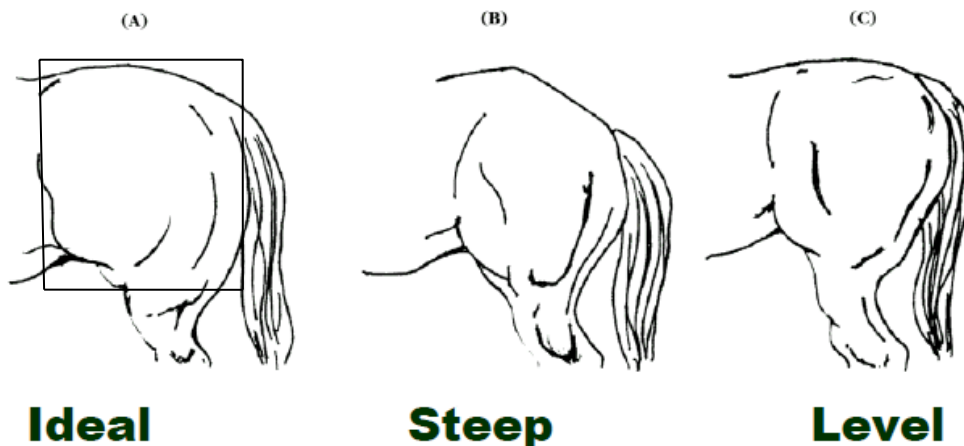

**(A) Ideal Croup/Hip-** should appear square and full when viewed from the side.

**(B) Steep Croup/Hip (a “goose rump”)-** Horses with steep croup are shorter usually, this reduces the range of motion to generate speed.The shorter croup provides a smaller amount of muscle attachment points.

**(C) Level Croup/Hip-** A flat, level croup is associated with hind limb action that occurs behind the hindquarters rather than underneath it. The level croup/hip has limited forward power and collection.



(Picture reproduced with permission of the AQHA)



## Refinement and Muscling

Refinement and muscling are important criterion in judging conformation classes. The purpose of judging is not to find the most muscled horse, but rather to find the individual with adequate muscling for the breed and sex of the animal. The correct individual will be a balanced athlete that is muscled uniformly throughout.

When judging the class it is more important for you as a judge to ask which animal is not adequately muscled rather than which animal is most heavily muscled. You must judge for overall qualities of refinement and proper muscling. Muscling is easily determined by comparing individual muscle groups such as the stifle, the gaskin and the forearm. Refinement is the quality appearance of the animal which indicates good breeding.

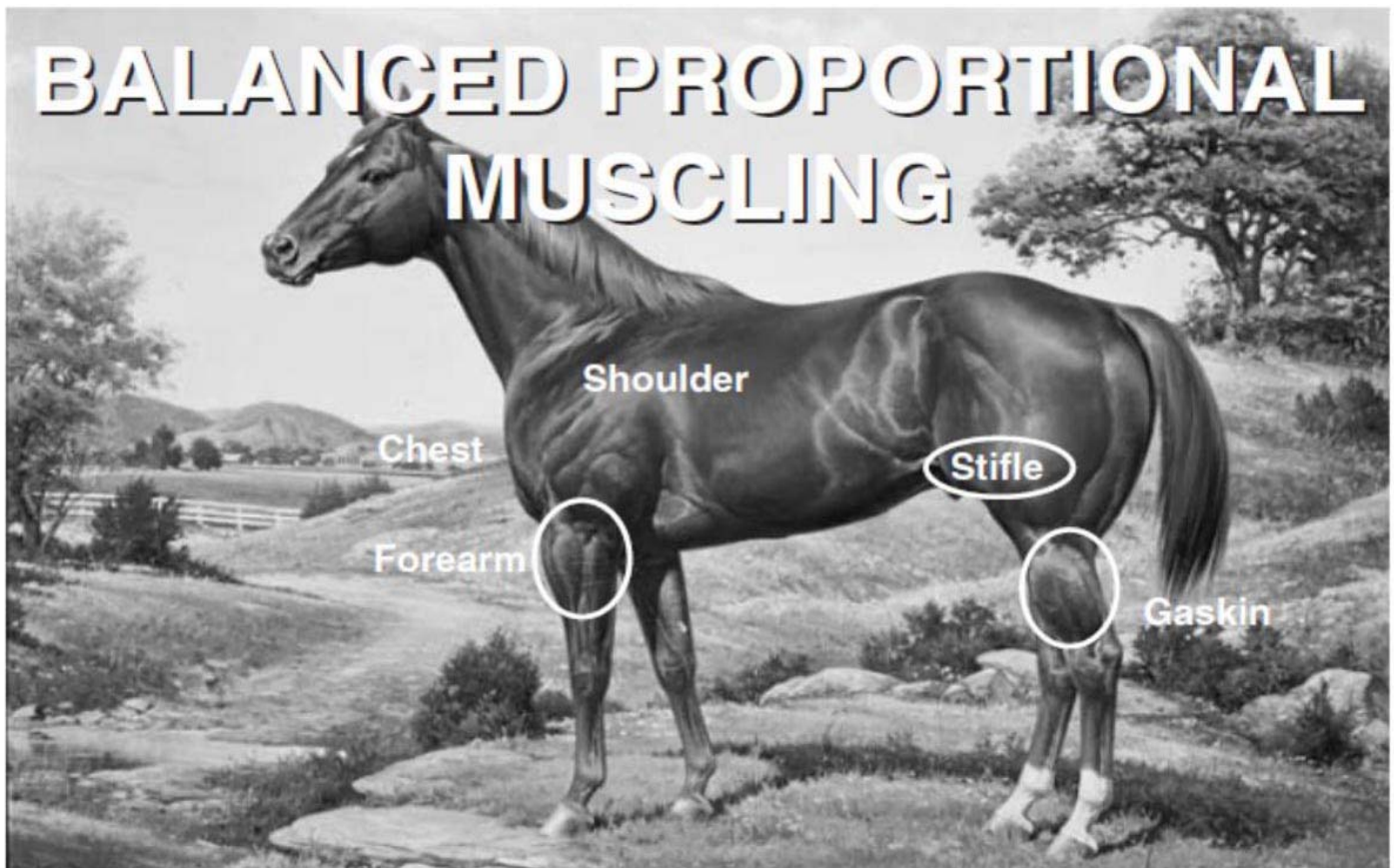

(Picture reproduced with permission of the AQHA)

# Proper Muscling = Quality and Refinement



## Front and Rear View of Areas of Muscling

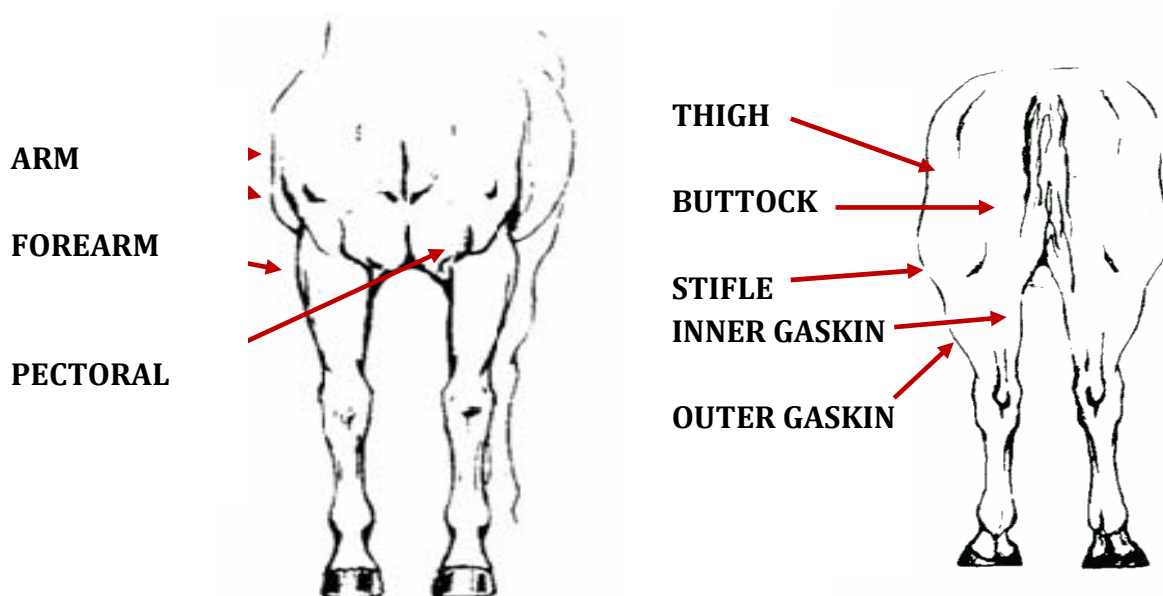

(Images reproduced with permission from Dr. Bob Mowrey: "Teaching Youth an Equine Conformation Judging System")

## Breed Characteristics

Breed characteristics refers to specific traits found in different breeds. Below we will list some common traits for several breeds:

**The Quarter Horse** – This class includes other stock type breeds such as paint and appaloosa. Most stock type breeds have a depth of heart girth and balanced wide-set forelegs that blend nicely into a long, sloping shoulder. The shoulder should taper into the gaskin and knees and continue to taper into a well structured cannon, fetlock and hoof . The horse will often stand between 14.2 and 15.2 hands with some individuals being slightly shorter or taller. The withers should be sharply formed and of medium height. The back of the quarter horse should be short and well coupled. The barrel should be deep, with well-sprung ribs that extend to the hips. The croup should be long and sloping and the animal should possess a long bottom line that extends to the flank of the animal.

Muscling should be deeply attached at the joints and appear long and smooth. The chest should form a wide “V” that ties well into the forearm. Muscling of the rear quarters of the stock horse should be heavy with depth and breadth. The leg should be full throughout the thigh, stifle, gaskin, and hock.

The head of the well balanced quarter horse should be short with wide-set eyes, well-shaped and wide nostrils, a short muzzle, with a firm mouth, and a prominent jaw. In the stallion there should be greater prominence of the jaw and the mare should have a more refined jaw.

**The Arabian** – the Arabian is a slightly smaller built horse usually standing between 14.1 and 15.1 hands. A distinctive characteristic of the Arabian is its small dished head, small muzzle, and very wide and deeply set dark eyes. The Arabian also has well-formed and wide nostrils, and a short span between eyes and muzzle. The ears are short and thin with an upward stance and curved tips. The Arabian possesses a long, arched neck set high in the chest and also ties high into the withers. The Arabian has long, sloping shoulders, long forearms, and short cannons. The back is mid-length tying into a horizontal croup and has a high, straight set tail.

**Tennessee Walker** – The Walking Horse can range from 14.3 to 17 hands in height. The shoulders are muscular and sloping which blend into a short back and a steep, sloping croup. The Walker has a well-shaped head, with intelligent eyes and pointed ears. The Walker also shows greater thickness in the throatlatch in comparison to some of the other breeds. The chest is deep and well defined. Due to the overstride of the Walker breed there is a need for the hocks to appear slightly sickled and the hoof mildly toed-out to accommodate the unique stride.

**Morgan Horse** – The Morgan is similar in height to the Quarter horse standing at a range of 14.1 to 15.2. This horse is built for stamina and work. The head is straight or may be slightly dished with wide set, and large eyes and a narrow muzzle. The ears are erect and alert and the Morgan has firm lips, large nostrils and a deep throatlatch, which is deeper than most breeds. The jaw is prominent on the Morgan and the head is carried high on a moderately crested neck.

The Morgan has well-angulated shoulders and deep, powerful musculature that blends into the short back. The Morgan has wide loins and a muscular croup. A side view of the Morgan shows a

topline that is gently curved from the poll to the back with a neck that ties into rather than in front of the withers. The legs are straight and sound with a short cannon and medium pastern.

**American Saddlebred** – This breed has a longer head, with a refined muzzle, small well-shaped, close set ears, and eyes that are set wide apart. The head is carried high on a long and arched neck. The throatlatch is clean and refined. The neck ties low into the chest and has a vertical appearance. The withers are high and the shoulder is long and sloping with a short back. The croup is level and the tail attaches high and is carried well. The legs are sharply defined with sloping pasterns, strong cannon bones and well-formed hooves.

**Draft Horse** – This breed is characterized by its sheer size and massive, powerful build. Standing 16.2 to well over 17 hands, the Draft horse is favored for its strength and power. The animal should be heavily muscled with a short, strong back, level top line, and a well-muscled croup. The Draft horse should appear compact and blocky with low set, shorter legs that provide strength when pulling. The forearm and gaskin should show well-defined musculature. The head should be well shaped and set atop a heavily muscled neck with upright shoulders and a heavily muscled and wide set chest.

**Hunter in Hand** – The Hunter horse has a long, lean appearance and often stands 16.-16.2 hands. The horse is longer, leaner, and deeper chested than other breeds. Although deep chested, it is narrow in appearance. The neck is refined with a clean throatlatch which blends into a long, well-sloped and flat-muscled shoulder. The head has wide-set eyes, a flat face and large, thin nostrils. The ears should be wide-set and small. The ribs behind the shoulder are flat, yet well-rounded and full over the ribcage. The hindquarters are powerful and have straight and correctly set legs with large, clean and flat joints.

## **Stallions and Mares**

Breeding classes should demonstrate either femininity or masculinity depending on the class. In the stallion class the individual should be more muscular than the female, with a stronger, crested neck, and a heavier jaw. The stallion should demonstrate masculine tendencies but possess a desirable temperament and be easy to handle.

In the mare classes the female should demonstrate feminine qualities with less muscling, a more refined head and neck and demonstrate broody characteristics. A broodmare must possess fineness in conformation be athletic and have a pleasant disposition. Such mares should mount high in the wither with the neck coming out at a marked angle from the body. The mare's shoulders should roll as she walks with the back legs reaching well under the body.

## Horse Colors and Markings

You must be able to identify a horse by its coat color and markings. Here is a list of colors and markings that you will need to know.

**Black**—uniform black color on the body, mane, and tail.

**Brown**— The body is usually brown or black with brown hairs located in the flank, muzzle, around the eyes, and on the tips of the ears.

**Chestnut**—The skin is often black or brown with red or reddish brown hair with similar colored mane and tail.

**Bay**—black mane and tail, with black points (black legs below the knees and hocks, black muzzle, and black tips on the ears), and a light or dark, reddish body.

**White/Albino**—pure white hair, pink skin and blue eyes.

**Gray**—A coat with white hairs intermixed with hairs of black. The mane and tail may be white, black or gray.

**Grulla**—A black mane and tail, often with black points with a gunmetal gray body that may have a dorsal stripe

**Dun**—A black mane, tail, and legs with a chamois colored body. They will often have a dorsal stripe.

**Buckskin**—black mane, tail, and legs with a light buff colored body. May have dorsal stripe.

**Palomino**—golden-yellow body color with a white or flaxen mane and tail.

**Sorrel** – Often a light reddish-brown with a flaxen mane and tail although the mane and tail may be the same color as the coat.

**Roan** – The roan has a coat with white hairs evenly intermingled throughout any other color. Many variations of roans, (red roan – bay with white), (strawberry roan – chestnut with white), (blue roan – black or dark gray coat with white hairs intermixed).

# Colors and Markings

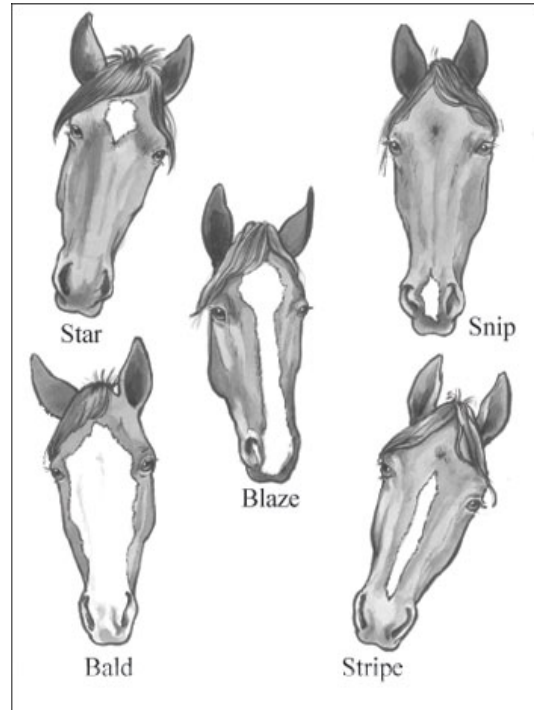
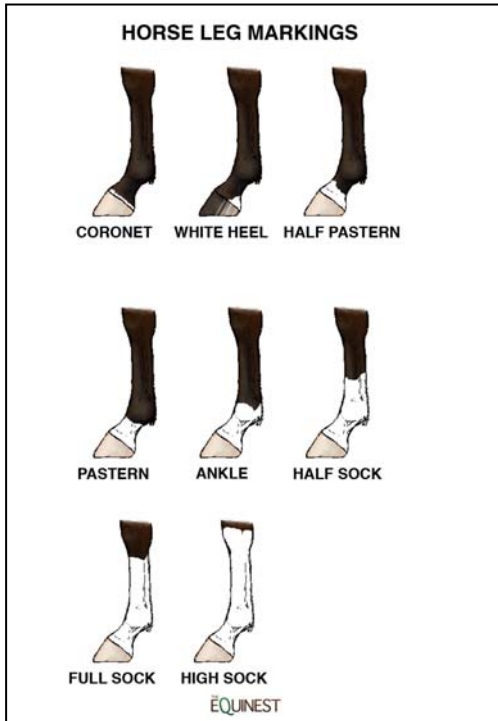

Source: <http://www.theequinest.com>



Source: ACES.nmsu.edu

## The Class

A halter class is defined as a class where the horse is judged based upon its conformation. Conformation is defined as the physical appearance of an animal due to the arrangement of muscle, bone and other body tissue.

### **The Ideal**

There is no perfectly conformed horse except in the eye of the artist. However, the American Quarter Horse Association has accepted the following “look” or image as its “Ideal” from which to establish halter horse judging criteria. The **Ideal** American Quarter Horse shown at halter is a horse that possesses the following characteristics: Eye appeal that is the result of a harmonious blending of an attractive head; refined throatlatch; wellproportioned trim neck; long sloping shoulder; deep heart girth; short back; strong loin and coupling; long hip and croup; well-defined and muscular stifle, gaskin, forearm, and chest; and straight and structurally correct feet and legs that are free of defects. The ideal should be an athlete that is uniformly muscled throughout.

### **Key Characteristics the Judge Should Evaluate:**

The most important criteria when judging a horse include:

**Balance**

**Muscle**

**Structure**

**Breed/Sex Characteristics**

**Travel and Movement**

## Judging the Halter Horse

Halter horse judging is a positive evaluation of balance, structural correctness, breed and sex characteristics, and muscling. When judging, it is important to make a positive evaluation of each horse’s resemblance to the ideal and to find the horse that best combines the traits listed above. It is easy to find what you don’t like about any animal and eliminate horses on that basis. However, when a positive evaluation is used, it produces a consistent result that finds the most complete horse. All judging involves the ability to find those animals that most resemble the ideal and to rank them accordingly. In order to judge halter horses it is important to have a thorough understanding of the traits used in the selection process. This process begins with balance.

# Judging Evaluation System



Fill in the blank spaces with the correct terminology

- 1) \_\_\_\_\_
- 2) \_\_\_\_\_
- 3) \_\_\_\_\_
- 4) \_\_\_\_\_
- 5) \_\_\_\_\_
- 6) \_\_\_\_\_

- 7) \_\_\_\_\_
- 8) \_\_\_\_\_
- 9) \_\_\_\_\_
- 10) \_\_\_\_\_
- 11) \_\_\_\_\_
- 12) \_\_\_\_\_

**Word Bank of Terms:**

- Thigh
- Slope of shoulder
- Croup
- Back
- Crest
- Loin

- Heart Girth
- Poll
- Flank
- Withers
- Head
- Barrel



# Judging Evaluation System



Fill in the blank spaces with the correct terminology

- 13) \_\_\_\_\_
- 14) \_\_\_\_\_
- 14) \_\_\_\_\_
- 14) \_\_\_\_\_
- 14) \_\_\_\_\_
- 14) \_\_\_\_\_
- 15) \_\_\_\_\_

- 16) \_\_\_\_\_
- 17) \_\_\_\_\_
- 17) \_\_\_\_\_
- 18) \_\_\_\_\_
- 18) \_\_\_\_\_

### Word Bank of Terms:

- |          |              |
|----------|--------------|
| Thigh    | Outer Gaskin |
| Flank    | Forearm      |
| Shoulder | Buttocks     |
| Stifle   | Hock         |
| Knee     | Cannon       |

(Worksheet 2:3) **Judging Evaluation System**

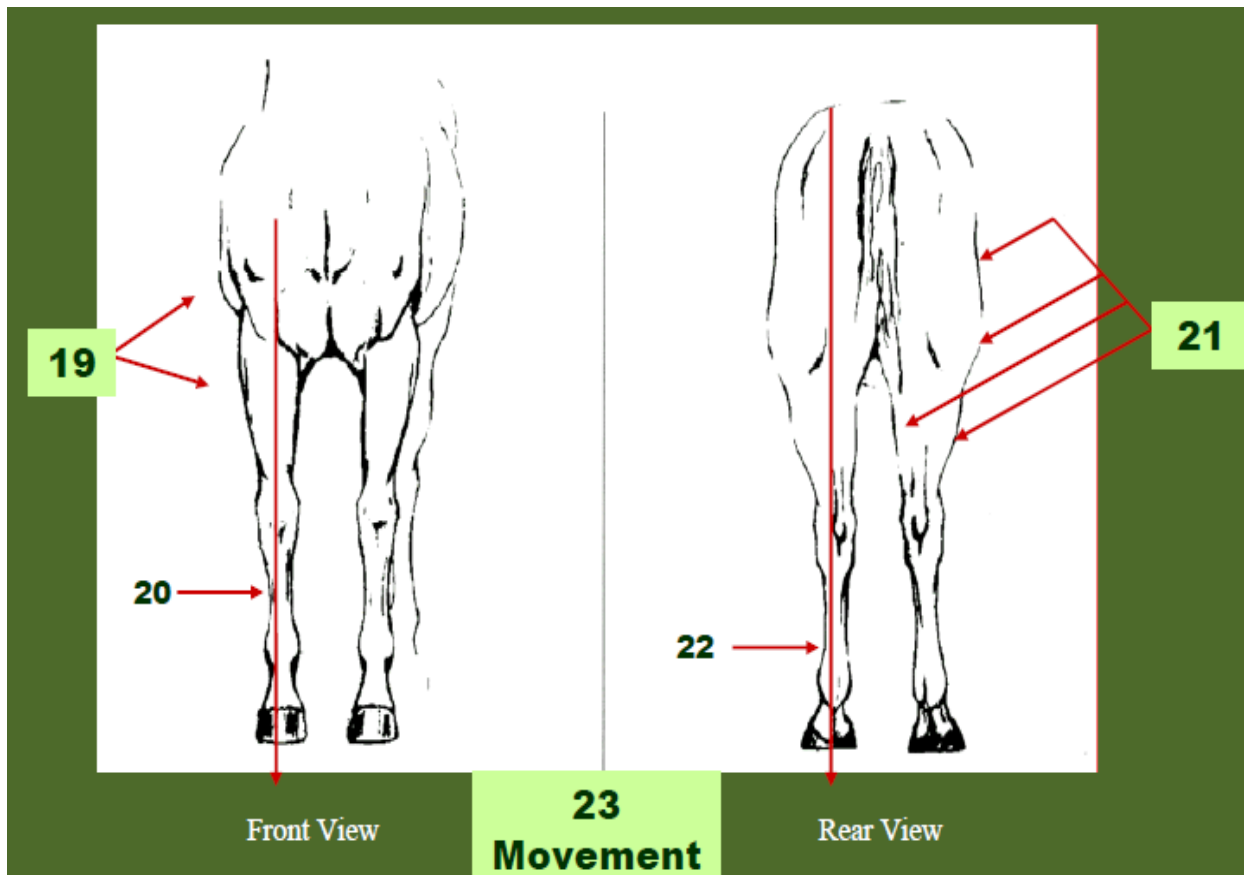

Fill in the blank spaces with the correct terminology

- 19) \_\_\_\_\_
- 19) \_\_\_\_\_
- 20) \_\_\_\_\_
- 21) \_\_\_\_\_
- 21) \_\_\_\_\_

- 21) \_\_\_\_\_
- 21) \_\_\_\_\_
- 22) \_\_\_\_\_
- 23) Visualized from front/rear view \_\_\_\_\_
- 23) Visualized from side view \_\_\_\_\_

**Word Bank of Terms:**

- Inner Gaskin
- Cannon
- Stifle
- Forearm
- Length of Stride

- Thigh
- Arm
- Outer Gaskin
- Trueness of Stride

# Practice Class of Halter Mares

Profile and Front view

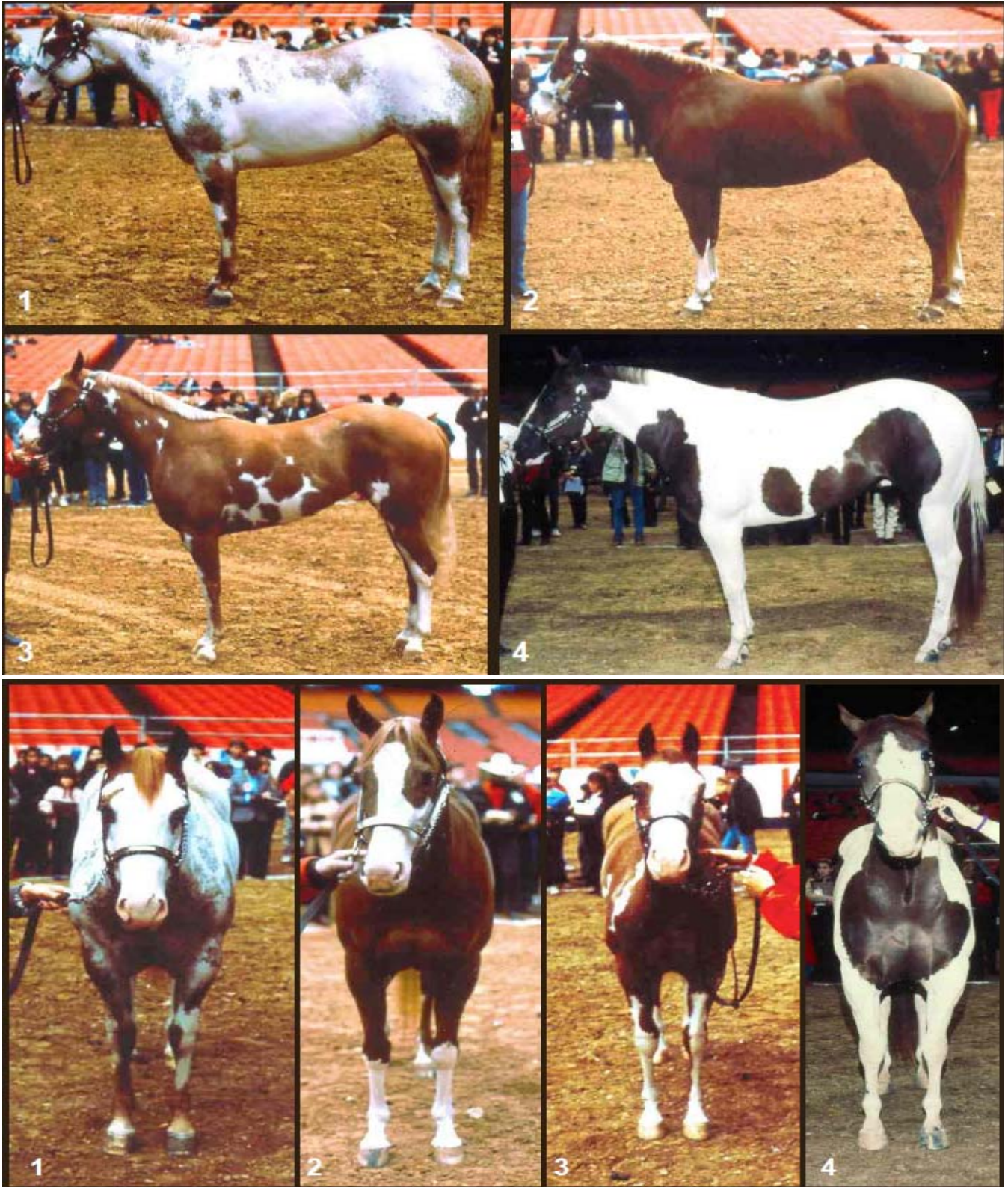

Rear view



Mare 1 side view



Mare 1 front and rear view

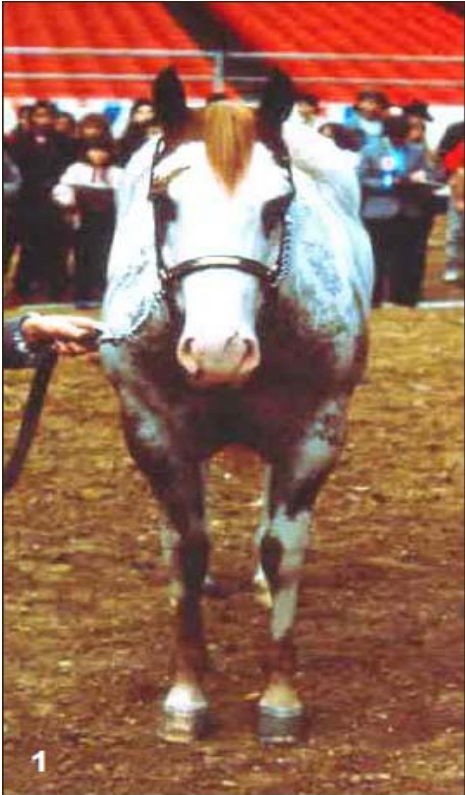

Mare 2 side view



Mare 2 front and rear view

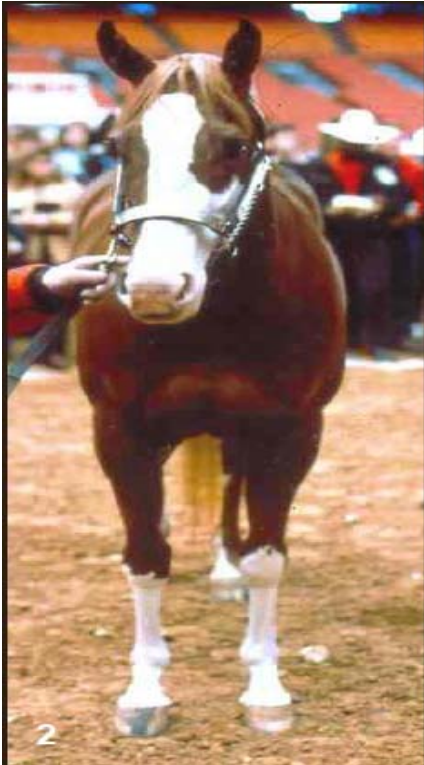

Mare 3 side view



Mare 3 front and rear view

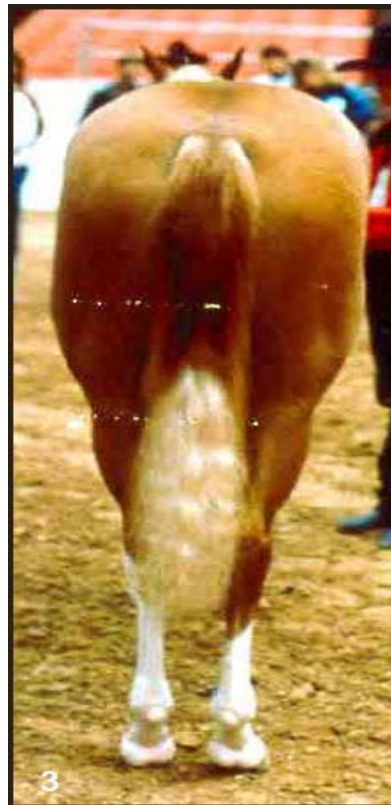

Mare 4 side view

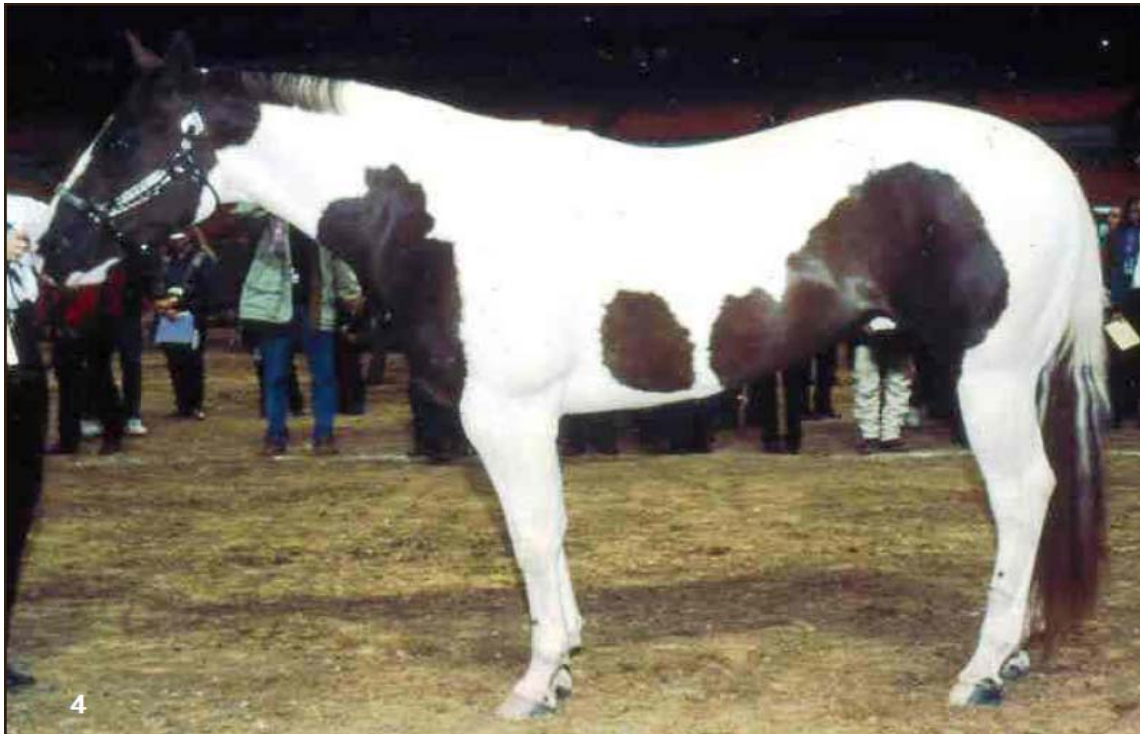

Mare 4 front and rear view



**How Would You Place This Class?**

**Mark Your Scantron!**





The following set of reasons allows the student to understand the method of delivering reasons and some of the terminology commonly used in judging. With each reason given, refer back to the pictures of the mares so that you may see why the class was placed as it was.

## 1-2-4-3

### Reasons:

I place this class of Halter Mares 1-2-4-3, initiating with a pair of more heavily muscled mares in 1 and 2, and concluding with the least balanced individual in 3. Ideally, 1 could be more refined about the muzzle; nevertheless, 1 is more proportional and a higher quality mare in my top pair of 1-2. 1 can more easily be divided into thirds having a more equally sized shoulder, barrel, and hip, being shorter over the back. Additionally, 1 offers a longer, thinner neck that ties higher into the chest. I do realize that 2 exhibits more bulge and flair to the forearm. 2 retains an advantage in muscling in my intermediate pair of 2-4, while also being the more feminine individual. 2 offers more substance and definition of muscling, when viewed from the front, having a more

prominent pectoral “V” with a greater circumference of the forearm. Furthermore, 2 is more refined about the face, with a brighter, more prominent eye. I will admit that 4 is shorter through the loin. Now in my concluding pair of 4-3, 4 is simply a larger hip complimented by a bigger stifle, tying into a more evenly balanced gaskin. In addition, 4 has a more desirable angle to the shoulder and hip while being shorter and more level over the top-line. I will concede, 3 offers a thinner neck. However, 3 is longer through the loin, uneven from wither to croup, while being the lightest made individual. Therefore, not only is 3 the least balanced mare, but also the least muscled. And so, 3 is last.

Thank You.

## Common Terms and Descriptions to Use in Judging

### Positive Attributes

- Had a more desirable slope to his/her shoulder and was neater and sharper at the withers
- More arch of rib
- More powerful topline
- Was shorter and stronger over the top
- Most broke, consistent, and relaxed horse

- Was a coarser moving individual
- Was shorter and stronger over the top
- Longer in his/her hip, shorter in his/her back, and showed more depth of heartgirth and hind rib, indicating more body capacity
- Taller at the withers and showed more uniformity of height from the croup to the withers
- Cleaner about the knees and hocks, with a finer and flatter cannon bone
- More elegant and refined head and neck
- More expressive about the eyes and ears
- Stood on straighter legs
- Showed more beauty, bloom and vigor
- Showed more femininity/masculinity
- Showed more breed character about the head and neck
- Thicker, heavier muscled stifle
- Cannon bones coming out more nearly to the center of the knee
- More substance of bone
- Showed a more refined/prominent jaw
- Longer neck that rose out of a more angulated shoulder
- Was tighter in the throatlatch and had a more naturally arching neck, which tied higher into his/her shoulder
- Stood on a wider, more desirable foundation
- More elegant and refined head and neck
- More expressive about the eyes and ears

## **Undesireable Traits and Faults**

- Long and weak over the topline
- Lacked balance and quality
- Smallest, least-balanced horse in the class
- Shallow through the heart girth
- Narrow between the eyes
- Post-legged, calf-kneed, cow-hocked, etc.
- Crooked through the front legs, with the cannon bone coming out of the side of the knees
- Low neck attachment
- Stood on bone too fine for her massive size
- Lacked style and presence
- Coarse at the withers
- Thick, less refined throatlatch
- Coarse hair/coat
- Lacked alertness

- Long-eared
- Unattractive, small eyes
- Parrot-mouthed
- Lacked volume and dimension through the hip, gaskin, and stifle
- Appeared to be the least athletic
- Lacked the length of stride when compared to (1,2,3,4)
- Lacked animation and style
- Showed the least breed character

## **“The IDEAL Show Types”**

Learning the Ideal Characteristics for Each of the Major Show Types

–English Type

–Hunter Type

–Stock Type



# English Type



English equitation is judged on the riders and their effect on the horse. The basics of equitation begins on the flat and progresses to over the fence work. The horse and rider are judged on their unity and harmony while working in the arena.

## **Attire:**

**Hard hat** – Either black or brown. In Over the Fence events the youth must wear a properly fitted and secured harness.

**Hair** – Must be neatly contained in a net, braid or bun or secured under a hunting cap.

**Shirts** – Ladies shirts are choker style, and choker should be secured with a pin. Men’s shirts should have a collar and a tie.

**Jackets** – Traditional colors are Navy, Dark Green, Grey, Black or Brown. Maroon and Red are not proper. A jacket is mandatory in equitation.

**Gloves** – Optional but desirable, and if worn should be dark colored. Hats, Gloves and Boots should match in color.

**Breeches** – Must be of the traditional shade of Buff, Khaki, Canary, Light Grey, or Rust.

**Boots** – Black or Brown.

**Jewelry** – Should be conservative and consist of small earrings that do not dangle.

**Hair Ties** – Bows are not acceptable.

**Belts** – Must be traditional and proper.

**Spurs** – Unrowelled type worn at spur rest with straps, slip on spurs are unacceptable.

**Crops** – Black or Brown, Dressage whips are unacceptable.

# The Horse Equipment

**Bridles** – Conservative leather type, plain or stitched with a cavesson and browband.

**Legal Bits** – Refer to the official Equitation Handbook for rulings on bits.

**Reins** – Must be leather. Rubber reins are prohibited except for jumping classes.

**Saddles** – Should be leather of traditional hunting or forward seat type.

**Saddle Pad** – Should be white or natural color to fit size and shape of saddle, square pads are unacceptable.

## **Optional Equipment:**

Standing or Running Martingale in over fence classes only

Breast Collars and Breastplates

Crops or bats

# Turnout

Turnout refers to the overall appearance of the horse and rider, the proper fit of the equipment and the presentation. Turnout is part of the overall score and must be taken into consideration when judging an equitation class. Braiding is optional but if the mane is braided the forelock must also be braided. The tail should not be braided unless the mane and forelock are also braided.

The quality of the equipment should not influence you as a judge, but rather the cleanliness, overall tidiness, and overall presentation of the horse and rider.

# Equitation on the Flat

## **Class Procedure:**

The Equitation on the Flat class is judged primarily on the ability of the rider to perform individual patterns, and work with correct riding positions and gaits. The judge is required to have all exhibitors work an individual pattern, and having the option of working all or just the finalists on the rail. Patterns should be drawn clearly and concisely with specific written directions and designed so the horse may be able to complete the pattern.

When markers are used they should be set far enough apart to allow all horses of any size to perform the maneuvers correctly. Markers should be placed in a position to allow for several full strides.



## **Rider's Position:**

The eye's of the rider should plan the next step of the horse. Excessive turning of the head to the inside of the circle, looking down at the horse's head, neck or shoulders should be considered a penalty. The rider must be positioned appropriately over the horse's center of balance with an upright but not rigid body. The judge should be able to draw an imaginary line from the rider's ear, shoulder, center of hip, and down to the back of the boot heel. Riders should sit in the center of the saddle not pushed back against the cantle. Shoulders should be straight and open and the rider's back flat, relaxed and supple. An overly stiff or arched back should be penalized. Elbows should be bent and kept by the rider's side while remaining flexible and following the horse's mouth.

The inclination of most riders is too much hand and too little seat and leg. There should be light contact from the hands to the bit. In proper position, the hands are just over and slightly in front of the withers and in direct line with the elbows and horse's mouth. Wrist should be straight not rigidly bent. The reins should be neither too tight nor too loose and the fingers closed around the reins. Bent wrists, loose reins, floppy arms and elbows should all be penalized.

A simple and excellent guideline to use in judging leg position is to observe the stirrup leather rule. When a rider is in balance, the leather should hang straight down from the point of attachment. If the rider's leg pushes the leather either forward or backward, the leg is not in the correct position. The seat of the equitation rider is not only for elegance but also for practicality, both of controlling the horse and allowing the use of minimal natural aids. The body, seat, hands, and legs are all natural aids.



## **The Walk:**

The walk should be a 4-beat gait with the rider in a vertical position with a following hand, one that yields to the natural movement of the horse's head and neck.

## **The Posting Trot:**

The posting trot is a 2-beat gait in which the rider should rise as the horse's outside foreleg moves forward and sit when it strikes the ground. When riders are at the posting trot they should close their hip angle forward to allow their torso to follow the horizontal movement of the horse. The upper body should be inclined about 20° in front of the vertical.



## **Right Diagonal on the Posting Trot:**

When asked for a right diagonal on the posting trot the rider is rising and falling with the right front leg of the horse. This is referred to as posting on the correct diagonal.

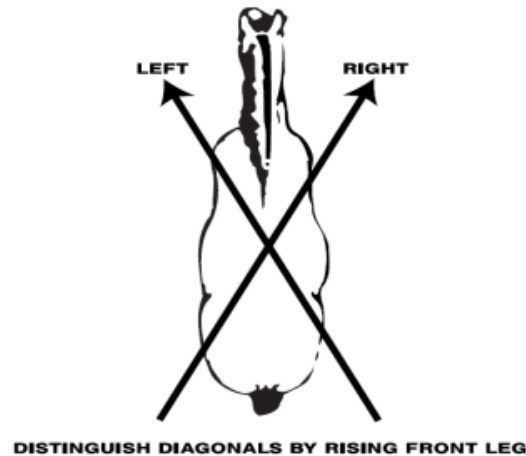

## **The Sitting Trot:**

At the sitting trot ( a two-beat gait) the upper body is only a couple of degrees in front of the vertical. This nearly upright position allows one's weight to sink into the horse's back. At the canter the body should be positioned slightly in front of the vertical, to match the upward motion of the gait. As the stride is shortened, the body should be in a slightly more erect position.

## **Two Point Position:**

In a two-point position the pelvis should be forward but relaxed, lifting the rider's weight off the horse's back and transferring the weight through the rider's legs. In this position the two points of contact between horse and rider are the rider's legs.

When properly ridden, a rider with deep ankles reflects downward distribution of the rider's weight and the rider's legs stay fixed on their horse's sides at all times. Hands should be forward, up the neck, not resting on the neck.

## **Hand Gallop:**

A 3-beat, lengthened canter ridden in two-point position: legs are on the horse's sides while the seat is held out of the saddle. With the aid of leg pressure, the rider causes the horse to lengthen its stride and increase its pace to a controlled, 3-beat gallop in hand. When at the hand gallop, the rider's angulation will vary somewhat as the horse's stride is shortened or lengthened. A good standard at a normal hand gallop should be about 30° in front of the vertical.

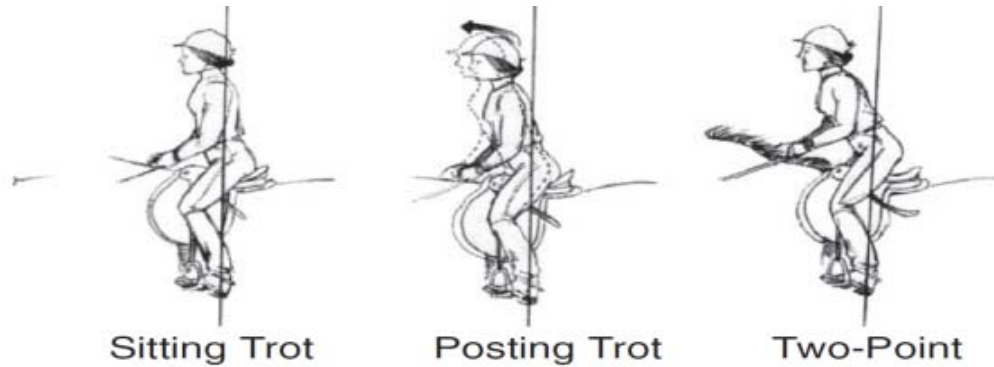

### **Exhibitor Turnout Faults: (avoids disqualification)**

- Loose, untidy hair (male & female)
- Crooked hat
- Loose choker, flapping tie
- Gaudy Jewelry
- Poorly fitted wrinkled, dirty or stained clothes
- Tattered gloves
- Unpolished boots
- Upside down spurs

### **Faults in overall Appearance of Horse: (avoids disqualification)**

- Poorly groomed, trimmed or conditioned horse
- Sloppy braiding
- Dirty, poor fitting tack and saddle pads
- Loose keepers on equipment
- Improperly fitted Martingales

### **Faults of the Position: (avoids disqualification)**

- Eyes down and looking down for leads and/or diagonals
- Head and/or shoulders crooked. Shoulders rounded forward and/or raised
- Stiff arms – unbent straight position
- Flapping elbows
- Open fingers – open pinky
- Uneven hands
- Hands too flat, too high, too low, spread too wide or too close
- Wrists bent inside or outside, wrists turned in or braced
- Wrists down or hands lower than wrists, referred to as puppy dog hands
- Uneven length of reins
- Improper hold of reins when using a double bridle or pelham

- Twisted reins of stirrup leathers
- Excessive body motion, Pumping
- Upper body too stiff (rigid), or too loose (sloppy)
- Excessive arch in back or roached back (rounded)
- Sitting behind vertical
- Shoved back into cantle



**PINCHED IN**

*Pressed downward from shoulder, stiffens entire back, neck and shoulders*

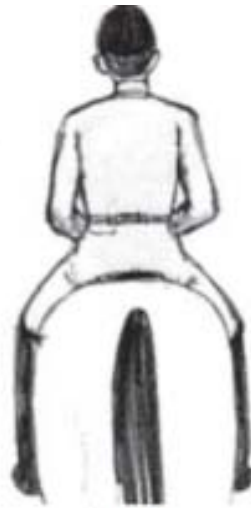

**OUT**

*Causes balance to come from arms, stiffens shoulder, neck and hands brace on horse's mouth*

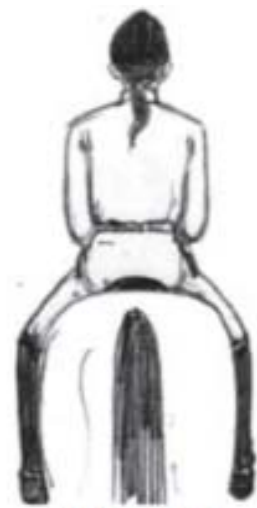

**NATURAL**

*Relaxed, comfortable resting easily at rider's side.*



**CORRECT POSITION**



**PELVIS TILTED TOO FAR FORWARD**

*Allowing leg to swing back to counter balance*



**PELVIS TILTED TOO FAR FORWARD**

*Placing weight on tailbone, makes leg swing forward*

## **Additional Faults of the Position: (avoids disqualification)**

- Splayed seat, thighs open
- Knees open or up, or a pinching knee
- Leg too far back behind the girth, leg too far forward in front of girth
- Foot too far into stirrup or riding on toes
- Stirrups too long or too short
- Toes too far out (calf gripping) and toes too far in ( no contact)



**LEG TOO FAR BACK, TIPPING RIDER FORWARD, OUT OF BALANCE**

- Excessive kicking by rider
- Horse with open mouth or kicking at rider's leg due to a fault of rider

## **Severe Faults of Overall Performance: (avoids disqualification)**

- Not completing pattern as described
- Failure to exhibit change of speed when requested
- Inclusion of maneuvers not specified
- Wrong diagonals
- Wrong leads
- Rough transitions
- Rhythm changes uncalled for
- Too slow = lack of impulsion, especially in pattern work
- Break of gait
- Poor circles
- Improper arc on curves or circles
- Poor halt or downward transition
- Back sluggish or crooked
- Use of crop or riding stick

## **Severe Disobedience of Performance:**(avoids disqualification)

- Omission or addition of maneuvers
- Turning wrong way
- Knocking over cone
- Working on wrong side of cones
- Kicking at other horse, exhibitor or judge
- Bucking or rearing

## **Disqualifications: (should not be placed)**

- Use of prohibited equipment
- Failure by exhibitor to wear correct number in visible manner
- Willful abuse
- Excessive schooling or training
- Fall by horse and/or rider

*Although the horse is only considered a prop in equitation, soundness is a consideration. Obvious lameness will be cause for disqualification.*

## **Suggested Scoring:**

Faults can be classified as minor, major, or severe. The judge will determine the appropriate classification of the fault depending on the degree and/or frequency of the infraction. A minor fault will result in a ½ to 4 point deduction from the exhibitor's score. An exhibitor that incurs a severe fault avoids elimination, but should be placed below all other exhibitors that complete the pattern correctly. A minor fault can become a major fault and a major fault can become a severe fault when the degree and/or frequency of the infraction merits.

## **Scoring may be on the basis of 0-20, with an approximate break-down as follows:**

**20: Excellent** – equitation including body position and use of aids. Pattern is performed promptly, precisely and smoothly.

**18-19: Generally Excellent** – performance with one minor fault in appearance and/or position of exhibitor or execution of the pattern (performance).

**16-17: Generally Good** – pattern execution an equitation with one minor fault in precision or execution of pattern (performance), or appearance and position of exhibitor.

**14-15: Average** – pattern lacks quickness or precision, or rider has obvious equitation flaws that prevent effective equitation, or commits two or three minor faults in the performance or appearance and position of exhibitor.

**12-13: One Major Fault** – or several minor faults in the performance and/or appearance and position of exhibitor that precludes effective communication with the horse.



# Western Pleasure, Hunter Under Saddle and Hunter Hack

## **Western Pleasure:**

Western Pleasure is an event judged on a horse's ability to be a pleasure to ride. To be a pleasure to ride, a horse must be broke and quiet, soft and smooth, and go with little restraint. In addition, a horse must meet the requirements of the class.

The official handbook of the American Quarter Horse Association describes the Western pleasure class in the following manner:

*Western pleasure is shown at a walk, jog, and lope each way of the ring. Horses are required to back easily and stand readily. A good pleasure horse has a stride of reasonable length in keeping with his conformation. He has enough cushion to his pastern to give the rider a pleasant, smooth ride. He carries his head in a natural position, not high and overflexed at the poll or low with the nose out. Credit should be given to a horse that is relaxed, but has his ears alert, looks balanced in his way of going, and is bright, as well as responsive to the reins. When asked to extend the jog, he moves out with the same smooth way of going.*

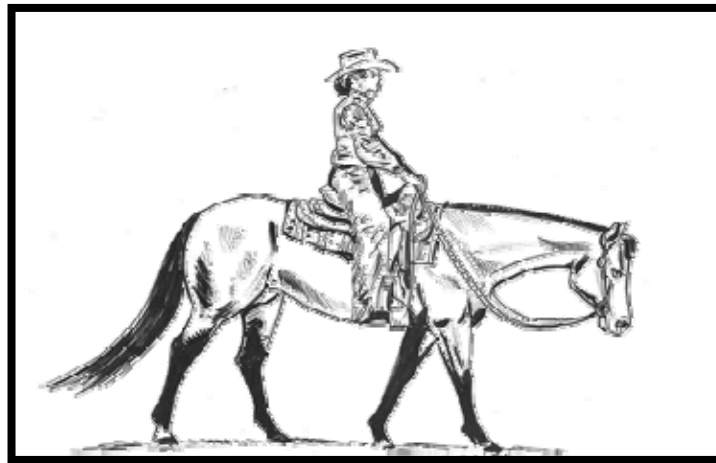

## **Attire:**

**Hat:** Straw or felt

**Shirt:** Long sleeved western style

**Jeans:** Wranglers will work

**Chaps:** Shotgun type, suede

**Boots:** Any western style boot with a heel

**Belt and buckle:** Leather belt, buckles may be show buckles or trophy buckles

**Gloves:** Leather gloves

**Western Tie:** Bolo ties are acceptable at some shows

**Jewelry:** may be bold and bright but should avoid dangle earrings

**Hair:** should be in a braid or bun. The hair should be neat in appearance

A common practice is to have all of the attire matching, Hat color, chaps, shirt, gloves and boots. The Western pleasure exhibitor is often well-coordinated and flashy in appearance.

## Acceptable Bits and Curb Straps:

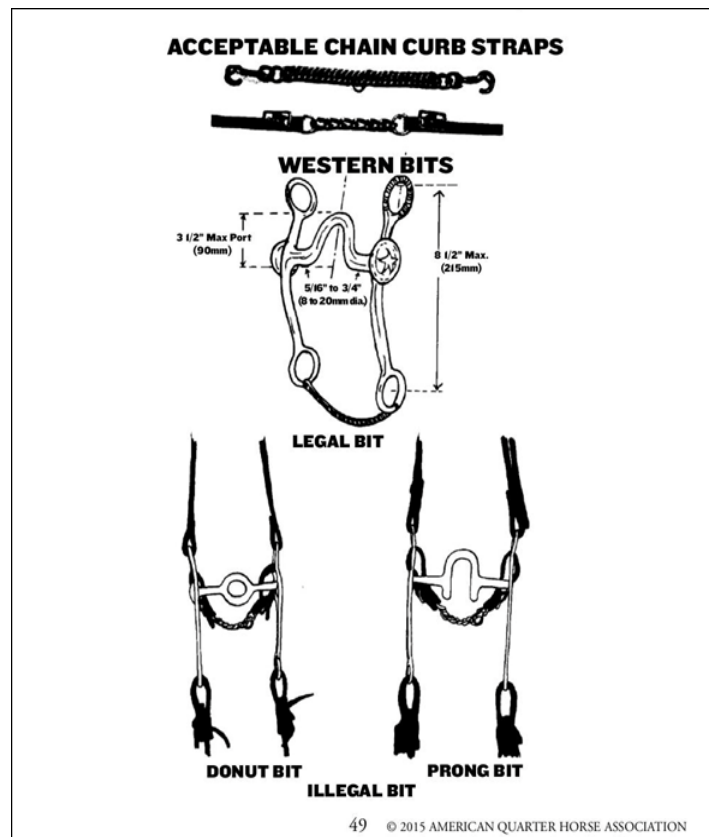

## **Ranch Riding:**

The purpose of the Ranch Riding horse should reflect the versatility, attitude, and movement of a working horse. The horse's performance should simulate a horse riding outside the confines of an arena and that of a working ranch horse. This class should show the horse's ability to work at a forward, working speed while under control by the rider. Light contact should be rewarded and horse shall not be shown on a full drape of reins. The overall manners and



responsiveness of the horse while performing the maneuver requirements and the horse's quality of movement are the primary considerations when judging this class.

## Judging:

Each horse will work individually, performing both required and optional maneuvers, and scored on the basis of 0-100, with 70 denoting an average performance. The required maneuvers will include the walk, trot, and lope both directions; and the extended trot and extended lope at least one direction as well as stops, and back. There is no time limit.

# Ranch and Western Riding Patterns:

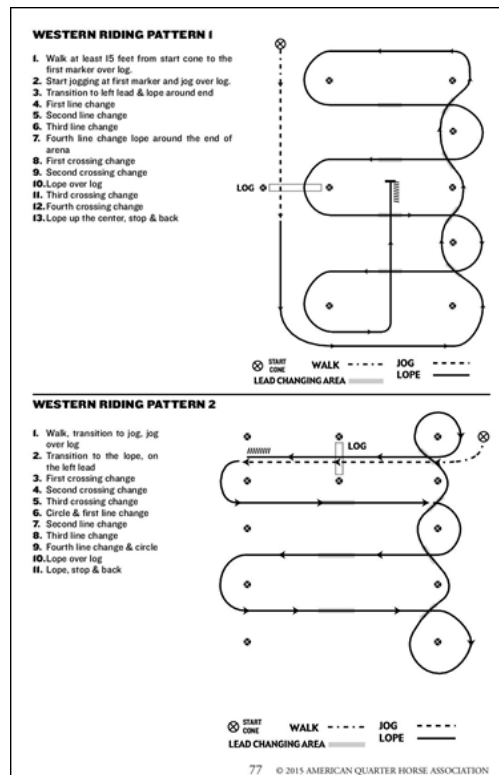
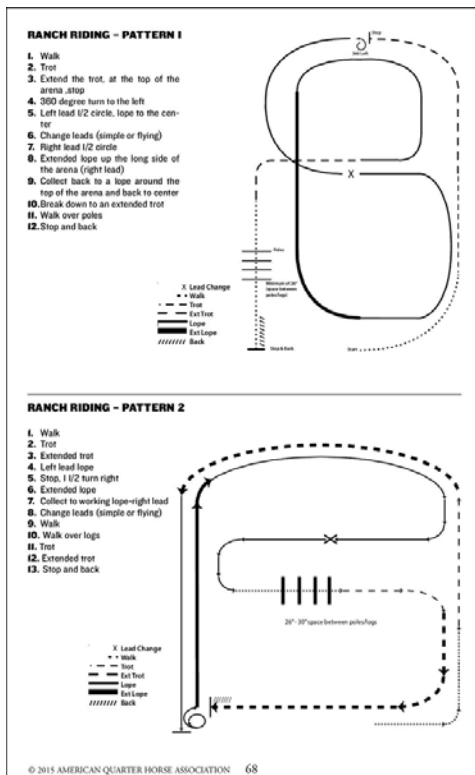

## The Walk:

The walk is a natural, flat-footed four-beat gait. The horse must move straight and true at the walk. The walk must be alert, with a stride of reasonable length, in keeping with the size of the horse.

## The Jog:

The jog is a smooth, ground-covering two-beat diagonal gait. The horse works from one pair of diagonals to the other pair. The jog should be square, balanced and with a straight, forward

movement of the feet. Horses walking with their back feet and jogging on the front are not considered to be performing the required gait. When asked to extend the jog, he moves out with the same smooth way of going.

## The Lope:

The lope is an easy, rhythmical three-beat gait. Horses moving to the left should lope on the left lead. Horses moving to the right should lope on the right lead. Horses traveling at a four-beat gait are not considered to be performing at a proper lope. The horse should lope with a natural stride and appear relaxed and smooth. He should be ridden at a speed that is a natural way of going. The head should be carried at an angle that is natural and suitable to the horse's conformation at all gaits.

## Faults:

Changing hands on reins, two hands on reins (unless showing with a snaffle or hackamore), more than one finger between reins, being on the wrong lead, excessive speed (any gait), excessive slowness (any gait), breaking gait, failure to take the called for gait when called for, touching the horse or saddle with free hand, head carried too low or too high, nosing out or flexing behind the vertical, opening mouth excessively, stumbling or falling, and use of spurs or romal forward of the cinch. Head carriage and disqualification.

## Class Placements:

Western pleasure classes are placed on four main criteria:

1. Broke and quiet
2. Soft and smooth
3. Functionally correct
4. Loose rein

It is possible to use a chart to aid you in placing the class. Imagine the class was evaluated as follows for the four main criteria:

---

HORSE	BROKE QUIET	SOFT SMOOTH	CORRECT	REIN LOOSE	TOTAL
1	4TH	3RD	4TH	4TH	15
2	3RD	4TH	3RD	3RD	13
3	2ND	2ND	2ND	1ST	7
4	1ST	1ST	1ST	2ND	5

THIS CLASS WOULD BE PLACED 4-3-2-1.

---

## **Scoring:**

Points are lost for a variety of infractions, below is a sample of some of the infractions. As a judge it is your responsibility to be familiar with the scoring process for each class. This information is available in the official handbook of the AQHA.

- Not performing the specific gait or not stopong when called for in the pattern
- Out of lead at aor befoe the marker, additional lead changes anywhere in the pattern
- Break of gait or walk or jog for more than two strides
- Blatant disobedience including kicking out, biting, bucking or rearing
- Use of either hand to instill fear or praise

## **Hunter Under Saddle**

Hunters Under Saddle should be suitable to purpose. Ideally, it should be a horse that is ridden through fields and woods, over brush and fence, following hounds chasing a fox. They should move in a long, low frame, and be able to lengthen their stride and cover ground in a traversing hunt country following hounds. They should be obedient, alert, and responsive to their riders. Quick, short strides should be penalized. Horses which move in an artificial frame, are over-flexed, or behind the bit should also be penalized. Hunters Under Saddle are shown at a walk, trot, and canter both ways in the ring. They may also be asked to extend the trot and hand gallop. Horses should back easily and stand quietly.

The purpose of the hunter under saddle horse is to present or exhibit a horse with a bright, alert expression, whose gaits show potential of being a working hunter. Therefore its gait must be free-flowing, ground covering and athletic. Hunters under saddle should be suitable to purpose. Hunters should move with long, low strides reaching forward with ease and smoothness, be able to lengthen stride and cover ground with relaxed, free-flowing movement, while exhibiting correct gaits that are of the proper cadence. The quality of the movement and the consistency of the gaits is a major consideration. Horses should be obedient, have a bright expression with alert ears, and should respond willingly to the rider with light leg and hand contact. Horses should be responsive and smooth in transition. When asked to extend the trot or hand gallop, they should move out with the same flowing motion. The poll should be level with, or slightly above, the withers to allow proper impulsion behind. The head position should be slightly in front of, or on, the vertical.

## **Judging:**

- This class will be judged on performance, condition and conformation. Maximum credit shall be given to the flowing, balanced, willing horse.
- Horses to be: shown under saddle, not to jump. Shown at a walk, trot and canter both ways of the ring. Horses should back easily and stand quietly.
- Reversed to the inside away from the rail.
- Horses may be asked to change to canter from the flatfooted walk or trot, at the judge's discretion.

## **Faults to be Scored According to Severity:**

- Quick, short or vertical strides
- Being on the wrong lead
- Breaking gait
- Excessive speed at any gait
- Excessive slowness in any gait, loss of forward momentum
- Failure to take the appropriate gait when called for
- Head carried too high
- Head carried too low (such that poll is below the withers)
- Overflexing or straining neck in head carriage so the nose is carried behind the vertical
- Excessive nosing out
- Failure to maintain light contact with horse's mouth
- Stumbling
- If a horse appears sullen, dull, lethargic, emaciated, drawn or overly tired
- Consistently showing too far off the rail
- (f) Faults which will be cause for disqualification, except in novice amateur or novice youth, which shall be faults scored according to severity:
- Head carried too low (such that poll is below the withers consistently)
- Overflexing or straining neck in head carriage so the nose is carried behind the vertical consistently
- (g) At the option of the judge, all or just the top 12 horses may be required to hand gallop, one or both ways of the ring. Never more than 12 horses to hand gallop at one time. At the hand gallop, the judge may ask the group to halt and stand quietly on a free rein (loosened rein).

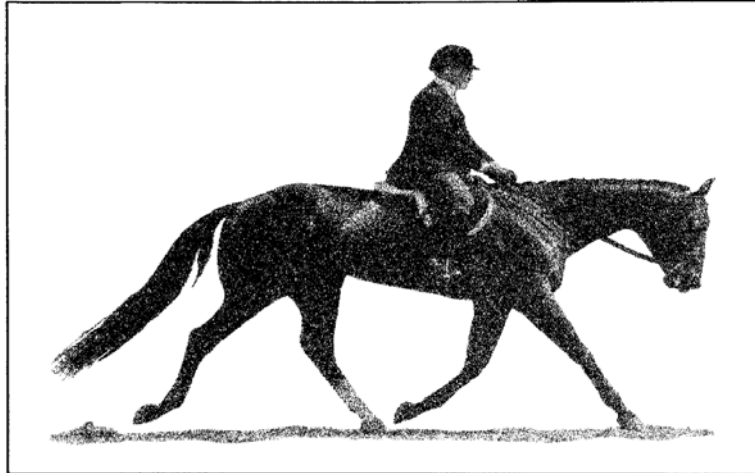

### Gaits:

**Walk** – forward, working walk, rhythmical and flat-footed: extremely slow, or “jiggy” walk to be penalized.

**Trot** – long, low, ground-covering, cadenced and balanced strides. Smoothness is more essential than speed. Extreme speed to be penalized. Excessive knee action to be penalized.

**Canter** – smooth, free-moving, relaxed and straight on both leads. The stride should be suitable to cover ground following hounds. Over-collected, four-beat canter to be penalized. Excessive speed to be penalized.

**Hand Gallop** – should be a definite lengthening of the stride with a noticeable difference in speed. The horse should be under control at all times and be able to pull up (not a sliding stop).

### Sample of a Chart to Aid in Judging:

---

HORSE	SOFT SMOOTH	WAY OF GOING	BROKE QUIET	CORRECT	TOTAL
1	3RD	2ND	2ND	3RD	10
2	1ST	1ST	1ST	2ND	5
3	4TH	4TH	4TH	4TH	16
4	2ND	3RD	3RD	1ST	9

THIS CLASS WOULD BE PLACED 2-4-1-3

---

# **Hunter Hack**

The purpose of hunter hack is to give horses and opportunity to show their expertise over low fences and on the flat. The hunter hack horse should move in the same style as a working hunter. The class will be judged on style over fences, even hunting pace, flat work, manners and way of going. The poll should be level with, or slightly above the withers, to allow proper impulsion behind. The head should not be carried behind the vertical, giving the appearance of intimidation, or be excessively nosed out, giving a resistant appearance.

Horses are first required to jump two fences, two feet three inches (68.5 cm) to three feet (90 cm). However, if the jumps are set on a line they are recommended to be in increments of 12 feet (3.5 meters) but adjusted to no less than two strides. A ground line is recommended for each jump.

Horses being considered for an award are then to be shown at a walk, trot and canter both ways of the ring with light contact. At the discretion of the judge, contestants may be asked to hand gallop, pull up or back and stand quietly following the last fence. When necessary to split large classes by running more than one go-round, finalists must both be re-jumped and reworked on the flat.

Placing for the class shall be determined by allowing a minimum of 70 percent for individual fence work and a maximum of 30 percent for work on the flat.

Faults over fences will be scored as in working hunter class. Horses eliminated in over fence portion of the class shall be disqualified. Faults (to be scored accordingly, but not necessarily cause disqualification during the rail work) include:

- Being on wrong lead and/or wrong diagonal at the trot
- Excessive speed (any gait)
- Excessive slowness (any gait)
- Breaking gait
- Failure to take gait when called
- Head carried too low or too high
- Nosing out or flexing behind the vertical
- Opening mouth excessively
- Stumbling

## **Faults:**

Faults which will be cause for disqualification, except in novice amateur or novice youth classes, which shall be faults, scored according to severity:

- (1) Head carried too low (such that the poll is below the withers consistently).
- (2) Over-flexing or straining neck in head carriage so the nose is carried behind the vertical consistently.

## **Fences:**

To be judged on manners, way of going and style of jumping, horses should have an even hunting pace and cover the course with free, flowing strides. Preference will be shown to horses with correct jumping style that meet the fences in stride without interrupting rhythm. Horses are to meet fences squarely, jumping at the center of the fence.

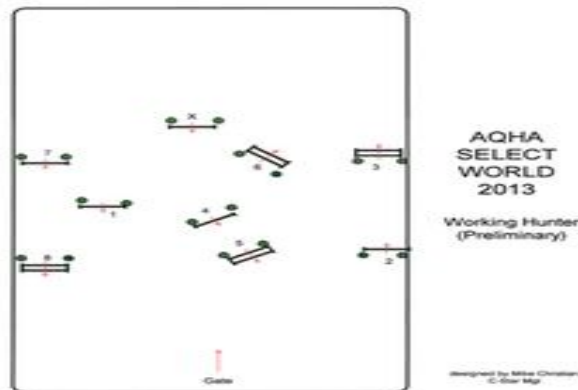

## **Terms to Compliment Pleasure Horses**

Below is a list of complimentary terms that you as the judge may use to describe the class. The terms are universal for most classes. As you progress in your judging, you will develop a vocabulary of terms and descriptions that you are comfortable using.

### **Opening Statements:**

- Overwhelmed the class with her style and easy, quiet way of going
- A placeable top, as he was the easiest, freest moving, most stylish horse that more closely typified the Ideal
- Considered a placeable top, as he was the most consistent and efficient performer
- Was a quieter horse, that slipped down the rail showing more brilliance and style
- Easier moving, showing more ability and a quieter pleasure horse disposition
- Appears to give a more comfortable ride

### **Statement for Broke and Quiet:**

- Most broke, consistent and relaxed horse
- A more relaxed, obedient mare
- Was more consistent and efficient throughout the performance

- Was a steadier, nicer mannered gelding
- Showed less resistance and hesitation to the rider's aids and cues
- Simply a more steady, solid and consistent performer
- Was the most broke and honest performer in the class
- Required less fixing and checking on the part of the rider
- He was more mindful of the bit, and carried his head more correctly
- Was quieter and calmer going both ways in the ring
- A more solid performer
- Showed to give a more pleasing ride, as she was more relaxed and less nervous
- Quiet, calmer more consistent performer

### **Back:**

- Backs easily without being forced
- Backed straighter and faster
- Backed with less mouthing of the bit
- More responsive when asked to back
- Responds by dropping off the bit
- Backing smoother and straighter

### **Transitions:**

- Accepted transitions with less resistance
- He (She) was more prompt and exact in the transition of gaits
- Quicker to make transitions through the gaits
- Responsive to rider's wishes
- Showed more response and give to his rider
- Picked up leads quickly and more correctly
- Goes both ways in a quieter fashion
- Smoother transitions
- Smoother and quicker in his transitions from the walk to canter
- Smoother, faster, more prompt transitions
- Accepted lead changes without hesitation
- Was more responsive to the rider's aids and cues

### **Attitude:**

- More acceptance to the bit, evidence of being quieter at the bit
- Is a willing worker
- Performed in a more workman-like manner
- More willing and obedient



- More obedient down the rail
- More alert and attentive
- More pleasant and willing to work
- Expresses a kinder, more agreeable temperament
- More pleasant and willing attitude
- Shows more expression while working
- Gives an appearance of enjoying the work
- Moved with less restraint
- Reined readily, without hesitation
- Show more feeling in his (her) mouth
- Responsive and agreeable to aids
- Performed his duties in a more willing and positive manner
- Readily yields to the rider's commands
- Was lighter and more responsive to the rider

### **Rein:**

- Moved on the loosest rein with the softest contact from the rider
- Traveled straighter down the rail at a more desirable speed
- More desirable drape of rein
- Leveler over the topline, more perpendicular in his headset as he went straighter down the rail on a much longer, more trusting rein
- Showed more flexion at the poll
- Looking straighter through the bridle while working of a looser rein
- Went on the longest rein with the lightest contact.

### **Headset:**

- Looked straighter through the bridle
- He carried his head so that his eyes were in the same plane or above his withers
- Was more mindful of the bit and carried his head more correctly (naturally).
- Carried his head with his eyes more nearly level to his withers
- His head was held more nearly perpendicular to the ground
- Had more contact with the bit
- Nicer headset, traveling with more flexion to the poll
- Held head more naturally and showed more alertness
- Had greater expression about the head
- Carries his (her) head more desirably
- Gives a more natural flex at the poll

- More relaxed through the jaw, yet more attentive about the head and ears
- Head held closer to vertical
- Cleaner throatlatch and a longer, more naturally arched neck
- Carries his head in a natural way

### **Quality and Conformation:**

- Bloomier and flashier, showing more quality
- More presence than the other participants
- Is a flashier, gelding (mare)
- Greater expression as she moved along the rail with a greater usage of eyes/ears
- More alert and attentive
- Showed more bloom and vigor to his (her) haircoat
- More balanced natural appearance

### **Hunter Under Saddle Terms for Complimenting Way of Going:**

- Freer moving in her shoulder as she showed with more extension of stride in all of her gaits
- Brisker moving horse that maintained more extension of stride throughout the class
- Showed more impulsion and drive off his hocks
- Was a lighter, softer traveling horse that showed more spring and animation of stride
- Showed more spring and flash in his movements
- Bolder moving horse that showed more length of stride, with greater impulsion and drive off his hocks
- A brisker-moving horse that maintained more extension throughout the duration of the class
- Lengthening equally from shoulder and stifle, achieving greater length with each stride
- Kept his hocks well underneath him showing greater drive from the hocks
- Moved forward into the trot with more hindquarter impulsion, more willingly without hesitation
- More sweeping trot
- Showed more energy and purpose of stride
- Exhibited greater forward impulsion from the hindquarters while at the canter
- A more energetic trot with more snap and flexion of knees and more hock action
- More snap, flexion and elasticity
- Engaged rear quarters with more drive

## **Terms Used to Criticize the Pleasure Horse:**

### **General Statements:**

- Lacks style
- Lacks pleasure horse type
- Lacks a pleasure horse disposition
- Simply could not compete with the style and movement of the top three horses
- Was the least broke, poorest mover in the class, simply lacking pleasure horse characteristics
- Could not compete in today's class
- Lacked the style and movement of the ideal pleasure horse
- Failed to perform his (her) duties in a pleasurable manner
- Did not display a pleasurable ride
- Lacked the consistency and efficiency of the horses placed above him
- Appeared to give an uncomfortable ride
- Lacked the natural abilities of a pleasure horse

### **Transitions:**

- Has slow transitions
- Has rough transitions
- Was slow and ill in the transitions of gaits, throwing his head and wringing his tail
- Failed to move smoothly through the gaits

### **Broke:**

- Was the least broke horse of the class
- Simply not broke
- Was a high-headed, nervous horse
- Inconsistent throughout the class
- Required the most restraint from his rider
- Travels with excessive speed and must be controlled with undue restraint
- Needed excessive restraint
- Is unresponsive to his/her rider
- Bucks
- Breaks gait
- Became more excited as the work progressed
- Lacks consistency at the lope, trot or jog
- Afraid of other horses

## **Back:**

- Did not back
- Was forced to back
- Was unwilling to back
- Hesitated and swished his tail excessively when asked to back
- Raised his head and mouthed the bit
- Lacking flexion and give to the bit when asked to back
- Backed crooked and unwillingly
- Opens mouth when asked to back

## **Quietness:**

- Works sour
- Seems unpleasant
- Was an unwilling performer
- Anticipated his rider's aids
- Listened to announcer
- Hard-mouthed, fights the bit
- Fights the bit and swishes tail
- Was an unwilling performer, evidenced by his wringing tail and bit chewing
- Excessively mouthed the bit
- Poorly mannered about the head
- Jawing and fussing at the bit
- Showed the least ability and the worst pleasure horse disposition

## **Softness/Smoothness of Motion:**

- Rough in her way of going
- Lacks smoothness
- Lacks suppleness
- Traveled rough, lacked smoothness
- He was rough at the walt, trot, lope, etc.
- Had a choppy, short stride
- Lacks animation
- Lacks balance
- Moves too slow/too fast
- Lacked a definite two-beat trot
- Lacked a definite three-beat lope, canter
- Was disunited at the lope (canter)

## **Rein:**

- Was ridden on the tightest rein
- Lacked the desirable length of rein
- Required the most restraint from the rider
- Rode with too tight of rein
- Reins were uneven

## **Headset and Balance:**

- Carried his head to high/low
- Traveled with her/his nose stuck out
- Heavy on the bit
- Was hard-mouthed, fighting the bit throughout the class
- Is behind the bit
- Was over-flexed and heavy on his front end
- Shis a heavy fronted horse
- Is above the bit and hollow down her back, lacking collection at the lope
- Is over-collected and behind the vertical
- Too high in his/her head carriage
- Nosed out on th emove, lacked poll flexion

# **Sample Sets of Reasons for Western Pleasure and Hunter Under Saddle**

## **Western Pleasure Reasons:**

I place this class with the most stylish mover (1) in the top pair, and left the poorer moving, most resistant horses in the bottom pair. After analyzing the top pair, I preferred to place 1 over 2. 1, the Palamino gelding, had a more stylish way of going, moving with more balance and cadence at the walk, trot and canter. 1 traveled with a more definite two-beat jog and three-beat canter, having more impulsion and drive from his hocks. It was also apparent that 1 was more collected at the canter. I'm aware that 1 did not possess the long, ground-covering stride of the ideal western pleasure horse.

In discussing the middle pair, I placed 2 over 3. 2 moved more consistent and calmer going both ways of the ring. She had a nicer head and neck carriage, showing more flexion at the poll and looking straighter through the bridle while working off a looser rein. 2 also had smoother transitions from the canter to the walk.

Proceeding on to the bottom pair, I favored 3 over 4. 3 showed to be a more athletic gelding, having greater length, as well as softness to his stride. 3 was also quieter and calmer going both ways in the arena, and showed more obedience to the rider. I realize that 3 worked off a tight rein and possessed little flexion at the poll.

In closing, I faulted 4 and placed him at the bottom of the class because he showed the most resistance to his rider's aids and cues, worked off a tight rein throughout the entire performance, and thus appeared to be the least enjoyable horse to ride.

It is for this reason I place this class of Western Pleasure 1-2-3-4.

*The second set of reasons gives you a different perspective on how to address the class and give your reasons.*

### **Sample Reasons for the Hunter Under Saddle:**

I placed this class of Hunters Under Saddle 2-1-4 and 3. I found the sorrel gelding to dominate the class in terms of his style, rhythm and length of stride as well as more closely fitting the description of the ideal hunter under saddle.

Judging the top pair, I placed 2 over 1. 2 exhibited a more desirable head carriage, keeping his eyes more nearly in the plane of his withers and less contact was maintained with his mouth by his rider throughout the class. Going along with this, he also reached further from his shoulder, extending well past the knees plus had more power and drive through his hindquarters, allowing him to achieve greater distance with every stride. I also noted that he cantered with a more nearly level topline, having more balance and rhythm as he traveled along the rail.

I do acknowledge that 1 moved out more briskly and with greater speed at the hand gallop.

Discussing the middle pair, I decided on 1 over 4. 1 was basically of a more desirable type, being especially taller and more fluid in his movement, deriving from a longer, lower, more efficient ground-covering stride. Not only that, but he was steadier and flatter at the canter, not to mention backed straighter and easier, tracking back with more definite two beats.

Coming to the bottom pair, 4 over 3 was chosen in a relatively close placing. 4 did show more length and reach of stride than did 3, having a longer, more sweeping trot and a more elongated stride at the walk.

I did recognize 4 climbed in front at the canter, whereas 3 was more level and traveled with his head at a more correct level. Be that as it may, I preferred 3 at the bottom of the class as he was decidedly shorter in the stride, lacking the smoothness and fluidity of a pleasurable horse to ride. In addition, he was more resistant to the bit, evident by his unwillingness when asked to back.

For these reasons, I derived a placing of 2-1-4 and 3.

## Judging the Reining Class



Two sets of rules most often used when judging reining, are those of the National Reining Horse Association (NRHA), and the American Quarter Horse Association (AQHA). Although there is little difference between the two, it is important to be aware of which set of rules are being followed in a judging contest.

In an approved reining class, any one of six approved AQHA reining patterns may be used. One of these six patterns is to be selected by the judge of the class and used by all contestants in the class. Each contestant will perform the required pattern individually and separately.

To rein a horse is not only to guide him, but also to control his every movement. The best reined horse should be willfully guided and controlled with little or no apparent resistance and dictated to completely. Any movement on his own must be considered lack of control. All deviation from the exact written pattern must be considered a lack or temporary loss of control, and therefore, faulted according to severity of deviation. Credit will be given for smoothness, finesse, attitude, quickness and authority in performing various maneuvers while using controlled speed.

## **Scoring:**

Scoring will be on the basis of 0-100, with 70 denoting an average performance.

The following faults will result in a no score:

- Failure to complete pattern as written
- Performing maneuvers other than in specified order
- Including maneuvers not specified, including but not limited to:
  - Backing more than two strides
  - A turn of more than 90° where not specified
- Equipment failure that delays completion of pattern
- Running away or failure to guide, where it becomes impossible to discern whether the entry is on pattern
- Jogging in excess of ½ circle or ½ the length of the arena while starting a circle, circling or exiting a rollback
- Overspins of more than ¼ turn
- Use of illegal equipment
- Willful abuse of an animal while in the show arena
- Using reins or romal as a whip
- More than one finger between reins
- Changing hands on reins
- Two hands on reins except with junior horses ridden two-handed, a bosal or snaffle bit
- Fall to the ground by horse or rider
- Balking or refusing a command

### **The Following Will Result in a Reduction of 5 Points:**

- Spurring in front of the cinch
- Use of free hand to instill fear
- Holding saddle or touching horse with free hand
- Blatant disobedience: kicking, biting, bucking, and rearing

### **The Following Will Result in a Reduction of 2 Points:**

- Failure to go beyond markers on stops or rollbacks
- Break of gait
- Freeze up in spin or rollbacks
- On walk in pattern, failure to stop or walk before executing a canter departure
- On run-in patterns, failure to be in a canter prior to the first marker



## **Starting or Performing Circles Out of Lead Will be Judged as Follows:**

- Each time the horse is out of lead the judge is required to deduct one point, which is accumulative
- The judge will deduct one point for each quarter of the circumference of the circle or any part thereof the horse is out of lead
- The judge is required to deduct ½ point for a delayed change of lead by one stride
- When a change of lead is specified immediately prior to a run at the end of the arena, failure to change leads will be penalized as follows:
  - Failure to change leads by one stride – ½ point deduction
  - Failure to change leads beyond stride but completed prior to next maneuver – 1 point
  - Lead is not changed prior to next maneuver – 2 points
  - In patterns requiring a run-around, failure to be on the correct lead when rounding the end of the arena will be penalized 1 point
  - Failure to be on the correct lead prior to the center point of the arena will receive a 2 point penalty

## **Other Faults that Result in Point Deduction:**

- Deduct ½ point for starting a circle at a jog or exiting rollbacks at a jog up to two strides
- Jogging beyond two strides, but less than ½ circle or ½ the length of the arena, deduction of 2 points
- Deduct ½ point for over or under spinning up to 1/8 of a turn, deduct one point for over or under spinning from 1/8 to ¼ turn
- Deduct ½ point for failure to remain a minimum of 20” from wall or fence when approaching a stop and/or rollback

## **Faults Against the Horse:** (does not cause disqualification)

- Opening mouth excessively when wearing a bit
- Excessive jawing, opening mouth or head raising on stop
- Lack of smooth, straight stop on haunches, bouncing or sideways stop
- Refusing to change leads
- Anticipating signals
- Stumbling
- Backing sideways
- Knocking over markers

## **Faults Against the Rider:** (does not cause disqualification)

- Losing stirrup
- Any unnecessary aid given by rider such as unnecessary talking, petting, spurring, quirting, jerking of reins, etc.
- Failure to run circles or figure 8 within the markers is not considered a fault depending on arena conditions and size: however, failure to go beyond markers on rollbacks and stops is considered a fault

## **Terms to Compliment a Reining Class:**

### **Opening Statements:**

- Exhibited the most agility and control
- Ran the fastest pattern with more control and authority
- He showed more willingness and precision in executing the prescribed pattern
- For the most part, he accomplished more of his pattern
- He simply got more done
- He was simply more fundamentally correct throughout the pattern
- She ran a more difficult and demanding pattern, and yet showed a more positive expression
- Exhibited more athletic ability and handle throughout the pattern
- Rider had a greater degree of handle on the horse, thus requiring less excessive reining and leg cues
- Was more stylish in the pattern, was a more definite, well-blended combination of fast and hard, soft and slow
- Her pattern was quicker and more correct, and she was obviously the top horse in today's class
- Placed at the top of the class because she exhibited a more complete picture of control, smoothness and speed
- Was a more natural, athletic horse, being a brighter, cleaner mover, holding a steadier rhythm and cadence
- The pattern was more accurate and was run with more effort and control from horse and rider
- Accepted the rider's contact, staying more supple and lighter through his neck
- Showed more finesse and control
- More exciting and pleasing form
- More accurate and relaxed throughout his/her pattern

## **Stops and Runs:**

- More controlled ideal stops
- Dropped deeper into the ground
- Dropped his hocks deeper into the ground
- Stopped with her haunches deeper in the ground
- Her stops were deeper and more completely shut down
- His stops were more stylish, being deeper with a longer slide
- He demonstrated deeper, straighter slides
- Performed a more correct sliding stop
- Stopped in a more relaxed manner
- Was a smoother, longer stopping horse
- Was more confident in his stops
- Exhibited a more controlled and relaxed sliding stop
- Stopped squarer
- Worked off his haunches and maintained movement in his front end, allowing him to have a more relaxed stop
- Dropped his hindquarters deeper into the ground, while keeping his front legs relaxed, allowing him to execute a more correct sliding stop
- His stops were executed with him being more over his haunches and more relaxed through his mouth, poll, neck, and loin
- Was a smoother stopping horse that stayed more relaxed and supple down his spine
- Moved into the stop with more confidence and authority, sinking deeper, curving his spine and crawling up front, thus sliding further and smoother
- For she was more correct and responsive in her stops, which were longer, harder, and deeper
- She was a softer, prettier moving mare, with stops that were deep and long
- Stopped with his haunches deeper in the ground, walking further up front
- He eased down into the dirt, holding both hocks steady in his longer slides, while moving more up front

## **Runs:**

- Drove out harder in the runs, stopped smoother and slid further
- Moved more freely into the rollback, driving out harder over the hocks
- Ran with greater speed and dispatch end to end, rolling back cleaner over the hocks
- Ran harder with less hesitation into his stops
- Ran with more authority and aggressiveness into her stops
- Came out of her rollbacks with more speed

## **Circles and Lead Changes:**

- Showed more size and speed variation to her circles
- Ran harder and faster circles
- Ran with more control and confidence in his circles
- His circles were performed more in the center of the arena
- Performed her circles in a more correct and precise manner
- Held his nose to the inside of the circle
- Running rounder circles
- Ran the circles more uniformly
- Drops back more obediently into the slow circles, holding his body correctly, while keeping a more steady pace
- Circles with a more correct arc through his body
- Performed his circles in a quieter and calmer manner ran flatter and smoother circles
- Laid down flatter, smoother circles
- Circled with her head, shoulder and hip more desirably arced in the direction of her circles
- Showed more variation and size of circles
- Showed greater control of the arena and ground, by staying more within the markers, while displaying smoother and more balanced circles
- Had a more correct degree of flex through the neck and shoulder
- She was softer in the bridle following a lighter rein in more precisely executed circles
- Ran his 8s with more speed and accuracy with more fluid lead changes
- Was more balanced in the figure 8s, opening his stride without hesitation in the fast circles
- Higher continuity of speed and size as he traveled through his circles
- Leaned rigcage and shoulder to the inside of the circles
- More alignment and glide to his circles
- Kept his nose tipped to the inside of the circle
- Exhibited smoother, simultaneous lead changes with less anticipation and hesitation
- Was more proficient in his lead changes, stops and turns
- Exhibited more natural, effortless lead changes
- Changing leads with greater dispatch
- Crisper and more direct lead changes

## **Spins, Rollbacks and Pivots:**

- Turned faster in the spins with his front loose and low
- Kept a lower center of gravity in his faster spins
- Faster spins while remaining flat and holding a more stationary pivot foot
- Held his body straighter in the spins, keeping his pivot foot in place while staying looser and lower in front as he reached around
- Each of his spins were faster than the preceding one
- Stayed down more, being leveler in the spins, crossing over cleaner with more reach, while maintaining a lower center of gravity
- Flatter, more consistent spins
- Smooth, faster and flatter spins
- He stayed down lower in his more brilliant spins
- She put in snappier spins
- Had more flexion to his hocks, maintaining a lower center of gravity while spinning
- More correct and agile spins in terms of his planting the pivot foot, shifting his weight more to his haunches, making his forehand maneuverable, exhibiting cleaner, faster, spins
- Showed more stability to his spins
- Ran harder from rollback to rollback
- Rolled back more over his haunches
- Performed a more correct 180-degree rollback
- Rolled over the hocks more correctly, with a more stationary pivot foot
- As he executed his rollback, he showed more control, aggression and a higher degree of difficulty
- Showed sharper, quicker pivots
- Showed more snap and finesse to her pivots
- Performed his pivots with more confidence and ease
- Showed more brilliance in her pivots
- Showed a crisper and more controlled pivot
- Showed a smoother pivot, crossing over cleaner and faster with is front legs

## **Back:**

- Was a faster and cleaner backing horse, with each foot falling equi-distant of the last
- Backed more readily over his tracks
- Faster, straighter back and settled more readily
- Lowered his head, tucked his nose and backed straighter and squarely over the hocks
- Backed faster with more ease
- Flexed her poll, relaxed her jaw and backed in a straighter fashion
- Was a faster, straighter backing horse
- Was more willing to settle after backing

## **Manners:**

- Was more responsive to the slightest cue
- Settled easier
- Worked more efficiently and with a more cooperative attitude
- Was a more willing worker, performing in a more positive manner
- More readily yielded to his rider's cues and aids
- Moved on a looser rein with less restraint on the part of the rider
- Performed with greater willingness
- Was quieter about the mouth and tail
- Was a more willing worker and was under more control by her rider
- Was quieter and calmer
- Performed her duties in a more workmanlike manner, showing more response and obedience to her rider
- Stood calmer after backing
- Showed more response to her rider
- Had less mouthing of the bit
- Was a more suitable reiner, as he was more broke
- Performed duties on a looser rein

## **Terms to Describe Faults in the Reining Class:**

### **General Statements:**

- He lacked the overall correctness and finesse of those I placed above him
- Lacked the control, finesse and style
- Lacked the polish, control and style that a knowledgeable horseman would have preferred
- Was the least willing, most unathletic horse in the class
- He showed to be under the least control by his rider

## **Stops and Runs:**

- Failed to stop
- Came out of his stops early
- Popped on his front end
- Was heavy on his front end
- Failed to completely stop on every stop
- Ran through his stops
- Was bouncy in his stops
- Stopped on his front end
- Extremely rough in his stops flipped his head in the stops
- Crooked stops
- Stopped short, splaying out thus losing his balance in the stops
- Did not use the ground efficiently when stopping
- Anticipated the stops, setting up early at each end
- Bolted into each run and was uncontrollable
- Took the bit and bolted coming out of rollbacks
- Flipped his head and ran away in the runs
- Changed leads continuously, anticipating going into each stop

## **Circles and Lead Changes:**

- Scurried around in a choppy, frantic manner in the circles
- Dropped his shoulder, drifting in and out of the circles
- Flipped her head, swinging her body off course in the circles
- Was stiff, lacking the desirable arc through her body
- Lacked size and speed variation
- Was slow and unwilling in the circles
- Shouldered out in each circle
- Was over-bent in the circles, shouldering out each way
- Was high and chargy
- She was out of control in the circles

## **Lead Changes:**

- Was late in lead changes
- Anticipated lead changes, dropping his shoulder to the inside of the new circle
- Was early in changes each time
- Drug the lead three-quarters the way around the first circle
- Missed his lead three strides going into his second circle

## **Spins, Rollbacks, and Pivot:**

- Lost her pivot foot, ending the spins far off center
- Hopped around in the spins
- Loped around in the spins
- Backed out of his spins
- Walked out of his spins
- Came up and out of the spins too short
- Hung in the spins
- Froze-up in the spins
- Shoulder out in the spins
- Was over-bent in the spins, losing his pivot foot, thus spinning over his middle
- Was too elevated and unaggressive in the first set of spins
- Stuck in the second set of spins
- Was slow and awkward in his rollbacks
- Rolled back over his middle
- Stuck in the right rollback, going away from the gate
- Pivoted over her front end
- Did not pivot
- Was slow and resistant during the pivots

## **Manners:**

- Was ill-mannered and resentful throughout the class
- Wrung his tail
- Flipped her head
- Opened his mouth and chewed his bit throughout the duration of the pattern
- Constantly mouthed the bit
- Lacked a positive expression and willingness
- Did not yield to the rider's commands
- Required the most restraint
- Was ridden on the tightest, least obedient rein

## **Back:**

- Did not or refused to back
- Was hesitant to back
- Drag her front legs when backing
- Flipped his head and wrung his tail when asked to back



## **A Sample Set of Reasons for a Reining Class:**

Sir, I placed this class of reining 3-4-2-1

In a class of four athletic and aggressive reining horses, I favored 3 over 4 in the top pair. 3 ran a harder, more demanding pattern and simply got more done. 3 showed greater size and speed variation in her circles. She ran more flowing circles, keeping her nose and shoulder to the inside of her circle while maintaining an over relaxed and natural arc to her body. She ran with greater authority and aggressiveness into her stops, melting her haunches deeper into the ground while maintaining movement on her front end, allowing her to slide further and deeper into the ground on every stop. She also executed more correct 180 degree rollbacks and 360 degree spins with greater brilliance and finesse. Aside from this, she backed more readily and quickly with a definite two - beat back. However, I will concede that 4 was a more athletic appearing mare that ran a faster pattern.

In the middle pair I placed 4, the gray gelding, over 2, the brown mare. 4 was a more willing worker, that performed his duties in a more positive manner. 4 was a more relaxed horse that more readily yielded to his rider's cues and aids. He executed smoother, flatter circles, more towards the center of the arena and performed simultaneous lead changes between these circles. He ran harder with less hesitation into his stops dropping his hindquarters deeper into the ground, while keeping his front legs relaxed, allowing him to execute more correct sliding stops. In addition, he showed greater snap and vigor to his rollbacks, as well as greater sharpness to his spins, turning more ideally over his haunches while maintaining a lower center of gravity. I recognize the 2 had a more desirable head carriage through her circles, keeping her head at a correct height.

Moving to the bottom pair, I liked 2, the brown mare over 1, the palamino gelding. 2 performed a more precise and controlled pattern, showing greater smoothness and consistency. 2 ran with more control and confidence in her circles, and more readily and correctly picked up her lead changes between circles. She moved with more speed from rollback to rollback, and drove her hocks deeper into the ground on her stops. But I criticize 2 because she was slow and hesitant in her spins, and I grant that 1 performed his spins with greater willingness.

Nevertheless, I fault 1 and placed him at the bottom of today's class, because he mouthed the bit and was resentful of his rider's demands. He failed to completely stop on every stop and failed to change behind ¼ of the third circle.

For these reasons I place this reining class: 3-4-2-1

# Reining Patterns

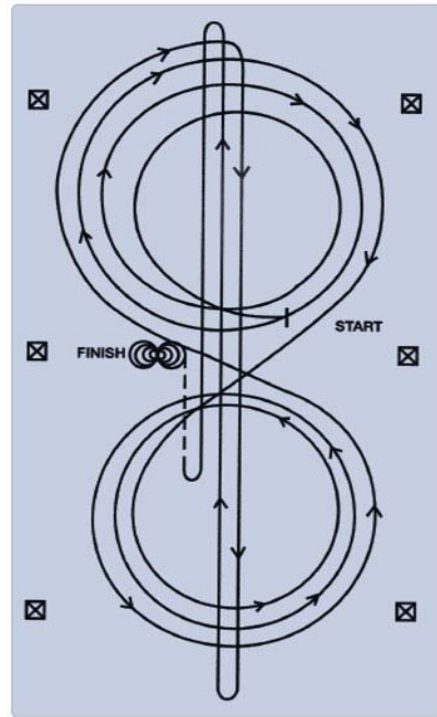
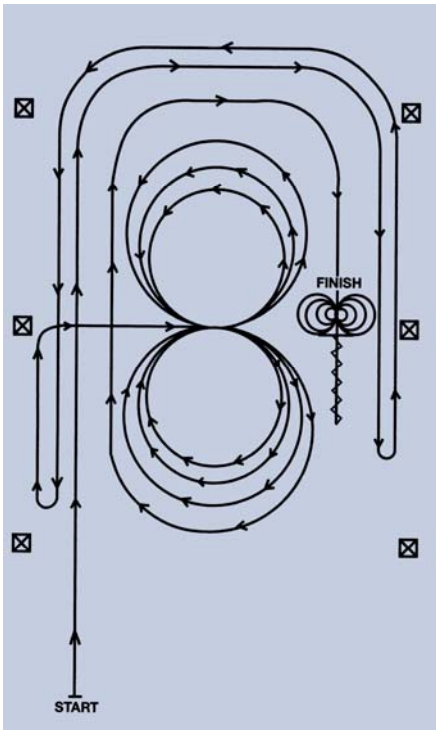
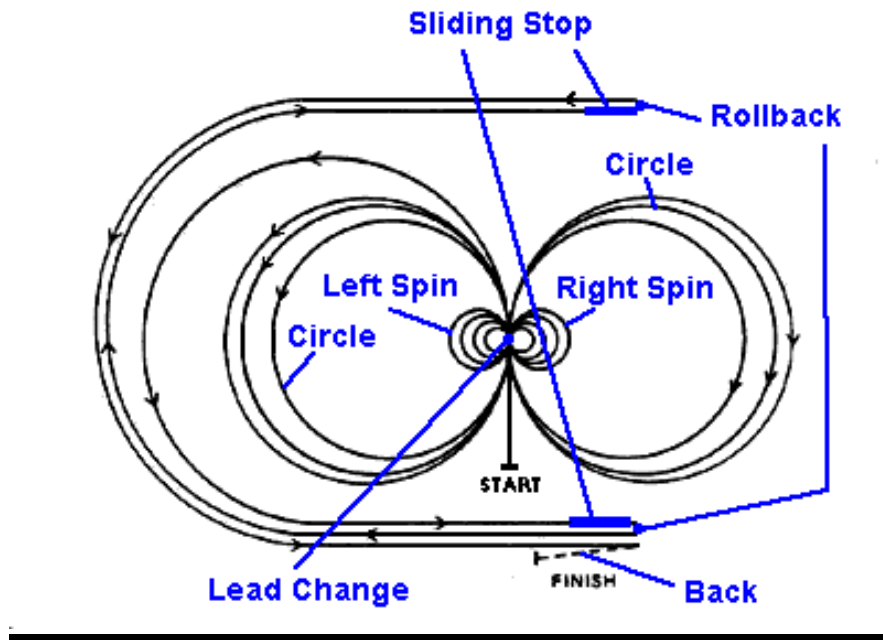

## Credits

Cover	Drawing and Silhouettes (Horse Classes and Horse Head) Mary Hewett
Page 8-9	Image (The Ideal Horse), <i>Judging Characteristics: AQHA Handbook for Showing and Judging</i> , 2015
Page 10	Image (Anatomy of the Horse), AQHA Handbook for Showing and Judging, 2015
Page 11-15	Image (Horse) Dr. Bob Mowery, " <i>Teaching Youth and Equine Conformation Judging System</i> ", North Carolina State University Definitions of Anatomy: AQHA Handbook for Showing and Judging, 2015
Page 12	Image (Horse's Head)
Page 13-14	Image (Horse) Dr. Bob Mowery, " <i>Teaching Youth and Equine Conformation Judging System</i> ", North Carolina State University
Page 16	Illustration (Unsound Horse) Dr. Bob Mowery, " <i>Teaching Youth and Equine Conformation Judging System</i> ", North Carolina State University
Page 18	Illustration (Common Unsoundnesses of the Horse) Un-named source, Google Images
Page 21-23	Images (Horse, Trapezoid) Dr. Bob Mowery, " <i>Teaching Youth and Equine Conformation Judging System</i> ", North Carolina State University
Page 24	Movement Definitions: University of Missouri – Columbia, Dept. of Animal Sciences, " <i>Selecting a Saddle</i> ". Image (Horse and Balance) Dr. Bob Mowery, " <i>Teaching Youth and Equine Conformation Judging System</i> ", North Carolina State University
Page 25	Image (Worksheet Illustrations) Dr. Bob Mowery, " <i>Teaching Youth and Equine Conformation Judging System</i> ", North Carolina State University
Page 27-34	Images and Diagrams (Horse Footfall Patterns, Deviations, Leg and Hindquarter) Dr. Bob Mowery, " <i>Teaching Youth and Equine Conformation Judging System</i> ", North Carolina State University
Page 32-33	Image (Horse) AQHA Handbook for Showing and Judging, 2015
Page 34	Image (Horse and Proper Muscling) Dr. Bob Mowery, " <i>Teaching Youth and Equine Conformation Judging System</i> ", North Carolina State University
Page 38	Illustrations (Head and Leg Markings) retrieved from: <a href="http://theequinest.com">http://theequinest.com</a> Illustrations (Coat of Many Colors, Appaloosa Markings) retrieved from: <a href="https://ACES.nmsu.edu">https://ACES.nmsu.edu</a>
Page 40-42	Images (Horses and Movement) Dr. Bob Mowery, " <i>Teaching Youth and Equine Conformation Judging System</i> ", North Carolina State University
Page 43-48	Photographs (Horses at a Show) Photographer: Chris Gay, Houston Livestock and Rodeo, 1996
Page 51	Drawing (The Ideal Horse) AQHA Handbook for Showing and Judging, 2015
Page 52	Drawing (English) AQHA Handbook for Showing and Judging, 2015

- Page 52-61 Images and Information (General English Attire, Equipment, Faults & Scoring) AQHA Handbook for Showing and Judging, 2015
- Page 55-57 Drawings (Leg, Post, and Trot Positions) AQHA Handbook for Showing and Judging, 2015
- Page 58 Drawing (Body Position) Un-named Source, Retrieved from Google Images
- Page 59 Drawing (Leg Position) AQHA Handbook for Showing and Judging, 2015
- Page 61-66 Images and Information (Western Pleasure: Attire, Equipment, Patterns, Faults, & Scoring) AQHA Handbook for Showing and Judging, 2015
- Page 66-69 Images and Information (Hunter Under Saddle: Judging, Faults, & Gaits) AQHA Handbook for Showing and Judging, 2015
- Page 69-70 Images and Information (Hunter Under Hack: Faults and Fences) AQHA Handbook for Showing and Judging, 2015
- Page 70-77 Information (Pleasure Horses) Common Knowledge Terminology
- Page 78-88 Information and Illustration (Reining Horse: Scoring & Faults) AQHA Handbook for Showing and Judging, 2015



State 4-H Office  
Cooperative Extension Service  
New Mexico State University

New Mexico State University is an equal opportunity/affirmative action employer and educator.  
NMSU and the U.S. Department of Agriculture cooperating.

